



SECURITY SENSOR

ZEBRA-24.60

User manual

CE Certificate of compliance

No. PS.19.015

TABLE OF CONTENTS

INTRODUCTION	3
1. Description and operation	4
1.1. Purpose	4
1.2. Specifications	5
1.3. Components	10
1.4. Construction and operation	13
1.5. Measuring instruments, tools and accessories.....	16
1.6. Marking	16
2. INTENDED USE	18
2.1. Use limits.....	18
2.2. Preparation for use.....	19
2.3. Installation and configuration.....	20
3. TECHNICAL SERVICE	47
3.1. General instructions.....	47
3.2. Safety measures	48
3.3. Technical service procedure	48
4. TROUBLESHOOTING GIUDE	50
5. STORAGE	51
6. TRANSPORTATION	52
7. Utilization	52

The present user manual applies to volumetric microwave security sensor ZEBRA-24.60 (hereinafter “Sensors” for all modifications) available in three modifications: **ZEBRA-24.60**, **ZEBRA-24.60.A** with an extended temperature range and **ZEBRA-24.60.BT** configurable via wireless Bluetooth interface.

The user manual contains information necessary for studying sensors and the principle of their operation, installation, powering and commissioning.

The transceiver unit generates a detection zone, which consists of 12 sub-zones. Each sub-zone can be controlled separately (arming/disarming, setting the sensitivity) by means of computer via USB, remotely via RS485 interface or Android device via USB with an OTG adapter, as well as via wireless Bluetooth interface (optionally).

The principle of operation is based on the method of linear frequency modulation. The super-high-frequency transmitter radiates electromagnetic oscillations in direction of the protected area. The electromagnetic oscillations are reflected from the goal and surrounding objects and reflected back into the super-high-frequency receiver.

Any motion in the detection zone causes changes in the received signal strength. These signal changes, caused by the Doppler Effect, are intensified and processed according to the algorithm. If the changes exceed the threshold value, the sensor generates an alarm. By triggering the relay opens its contacts.

Only qualified personnel familiar with this user manual and operation of sensors should install and adjust the sensors.

All commissioning works and services on-site should be carried out by personnel who have studied this manual.

1 Description and operation

1.1 Purpose

1.1.1 The sensor is intended to protect perimeter sites, open and closed areas of objects and to detect persons moving upright or bent within the detection zone.

The sensor can be used to protect fences against overclimbing and windows against intrusion.

ATTENTION! THE POSSIBILITY OF APPLYING SENSORS ON OBJECTS WITH POWERFUL SOURCES OF ELECTROMAGNETIC RADIATION (RADAR, RADIO TRANSMITTING STATIONS, ETC.) IS DETERMINED IN TRIAL OPERATION.

1.1.2 The sensor generates an alarm:

- When a person weighing 50 kg or more and 165 cm in height or taller crosses the detection zone moving upright or bent at a speed from 0.1 up to 8 m/sec with the minimum detection probability 0.98
- When a remote control signal is applied to the transceiver
- By an unauthorized access to controls both if there is power supply or not
- In the absence of supply voltage

1.1.3 The sensor generates a trouble signal:

- When the power supply voltage drops below 10V
- In case of malfunction of the sensor when it is controlled automatically

1.1.4 The following factors don't cause an alarm:

- Birds and small animals with the linear dimensions up to 0.3 m moving in the detection zone at a distance less than 5 m from the sensor
- Operation of the second sensor with a different frequency letter on the same area with partial overlap of the detection zone

- A single vehicle moving parallel to the axis of the detection zone at a minimum distance of 3 m from its border
- A traffic flow moving outside the detection zone and at a minimum distance of 20 m from its border
- Rain and snow up to 10 mm/h
- Thick fog
- Solar radiation
- Wind speed up to 20 m/sec
- Influence of ultra short waves emissions of the range 433 MHz and mobile phones at a distance of more than 0.5 m from the sensor

ATTENTION! THE COMBINED EFFECTS OF WIND AND RAIN (RAIN FRONT) CAN CAUSE NUISANCE ALARMS.

1.1.5 Operating conditions

The sensors are resistant to environmental conditions and mechanical stress.

- The temperature range for ZEBRA-24.60 and ZEBRA-24.60.BT: -40° to +80°C
- The temperature range for ZEBRA-24.60.A: -60° to +80°C.

The sensors are configurable via Bluetooth interface at - 25° to + 75°C.

- The relative humidity up to 100% at a temperature of + 40°C without moisture condensation.

1.2 Specifications

1.2.1 Figure 1.1 and tables 1.1, 1.2 show configuration of the detection zone of sensors mounted on poles, minimum and maximum detection range, detection width and detection height.

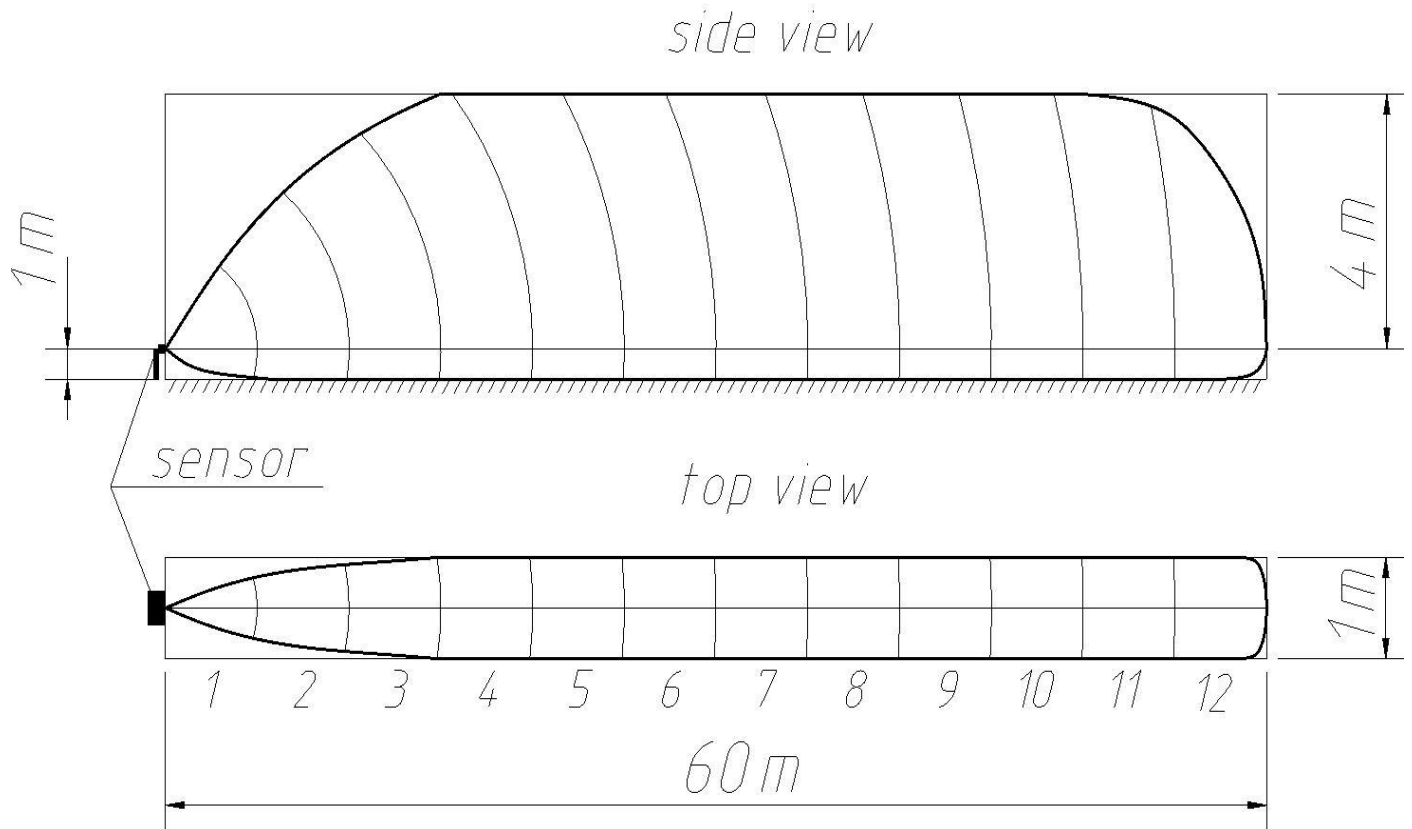

Figure 1.1 – Maximum detection zone of the sensor mounted on the pole 1 m above the ground

Table 1.1 – Number and range of each sub-zone.

Sub-zone number	Sub-zone range
1	0-5 m
2	5-10 m
3	10-15 m
4	15-20 m
5	20-25 m
6	25-30 m
7	30-35 m
8	35-40 m
9	40-45 m
10	45-50 m
11	50-55 m
12	55-60 m

Note: the distances given in table 1.1 are approximately and can be slightly different depending on the factory adjustment errors, sensitivity settings, surface effect and reflecting objects in the detection zone.

Table 1.2 – Minimum and maximum detection zone parameters.

Modification	Maximum detection range, m (12 cross subzones, each 5 m)	Minimum detection range, m	Detection height, m	Detection width, m
ZEBRA-24.60 ZEBRA-24.60.A ZEBRA-24.60.BT	60	5	8	1

1.2.2 Detection zone parameters of ZEBRA-24.60 meet ones given in item 1.2.1 under conditions of items 1.2.2.1, 1.2.2.2.

1.2.2.1 The protected area (site) should meet the following requirements:

- a) Maximum height of irregularities shouldn't exceed ± 0.3 m
- b) Height of the grass cover shouldn't exceed 0.2 m
- c) Height of the snow cover shouldn't exceed 0.3 m
- d) On the site avoid tall grass (higher than 0.5 m), bushes and trees at a distance less than 5 m from the boundary of the detection zone
- e) Don't direct the sensor to surfaces with high reflectivity (metal, reinforced concrete, etc.), since sensitivity to vibrations and movements against the background of such surfaces increases essentially
- f) Movements of people are allowed at a distance of minimum 2 m from the axis of the site with a detection range of 40 m (at a distance of 3 m with a detection range of 60 m). In direction of radiation movements of people is allowed at a distance of minimum 10 m form the detection zone boundary.

Movements of transport are allowed at a distance of minimum 4 m from the axis of the site with a detection range of 40 m (at a distance of 6 m with a detection range of 60 m). In direction of radiation movement of transport is allowed at a distance of minimum 20 m from the detection zone boundary

- g) When the sensor is used between fences the exclusion zone (distance between fences) should be minimum 3 m. Movements of people and vehicles closely behind fences made of metal, metal mesh and concrete will not cause nuisance alarms
- h) When installing the sensor, exclude the water flow near the sensor. The water sheets should be excluded throughout the detection zone.

The outer block of the conditioner may cause nuisance alarms. In this case, it is recommended to put a shield (a metal sheet) in front of the conditioner.

1.2.2.2 A secured room should meet the following requirements:

- a) Don't mount sensors on walls subjected to constant vibrations
- b) Animals, small birds, vibrating or moving objects (vent lights, doors, air-exhausters, etc.) should not be in the secured room.

1.2.3 Operation frequency is from 24.05 to 24.25 GHz.

1.2.4 Sensors have one of 5 frequency letters L1, L2, L3, L4, and L5 in order to avoid the mutual influence of sensors installed on one object.

1.2.5 The sensor is ready for operation within 15 seconds after applying power.

1.2.6 The alarm duration is minimum 3 seconds.

1.2.7 The sensor goes back to the standby mode within 5 seconds after alarm.

1.2.8 The sensors ZEBRA-24.60 and ZEBRA-24.60.BT are powered from 10 up to 30 V DC with the maximum pulsation of 0.03 V. The maximum power consumption is 1.5 W.

The sensor ZEBRA-24.60.A is powered from 20 up to 28 V DC. The current consumption is 270 mA at a voltage of 24 V.

- 1.2.9 The sensor ZEBRA-24.60.A has a built-in automatic heat stabilizer, which is activated when the ambient temperature drops below minus 25 ± 5 °C and ensures operation of the sensor at minus 60 °C.
- 1.2.10 Executive relay parameters: the highest switched current is 0.1A, the maximum voltage is 50 V and the maximum resistance is 130 Ohm in the closed condition (together with the lightning guard elements).
- 1.2.11 Tamper button parameters: current up to 0.2 A, voltage up to 80 V.
- 1.2.12 Input circuits of the sensor are immune to short-term electromagnetic interferences (including thunderstorms) with an amplitude up to 900 V.
- 1.2.13 The sensors have the IP55 protection level.
- 1.2.14 The sensors are configurable and controllable via USB-interface using a notebook on the Windows platform.
- 1.2.15 The sensors are configurable and controllable via USB-interface using a tablet on the Android platform.
- 1.2.16 Remote configurations via RS-485 interface are possible.
- 1.2.17 The sensors ZEBRA-24.60.BT are configurable and controllable via Bluetooth interface using a tablet on the Android platform.
- 1.2.18 Remote control of operability is possible (see items 3.3.2.1).
- 1.2.19 The sensors have an automatic control of operability.
- 1.2.20 The sensors are capable of being rotated:
 - 90° in the horizontal plane on the bracket and 40° in the vertical plane upwards and 15° in the vertical plane downwards
 - 360° relative to the pole.
- 1.2.21 Mean time to failure: minimum 60000 hours.
- 1.2.22 Life time: 8 years.
- 1.2.23 Maximum weight with fastening elements, kg: maximum 1.5 kg.

1.3 Components

1.3.1 The sensors have three modifications (please see table 1.2).

Table 1.2 – Modifications of ZEBRA-24.60

Modifications
ZEBRA-24.60
ZEBRA-24.60.A
ZEBRA-24.60.BT

1.3.2 Table 1.3 shows the completeness of sets.

Table 1.3 – Delivery set of ZEBRA-60(24)

Name	Q-ty	Note
1	2	3
ZEBRA-24.60		
Transceiver	1	
Mounting kit	1	see table 1.4
Kit of tools and accessories	1	see table 1.5
User manual	1	
Passport	1	
Package	1	
ZEBRA-24.60.A		
Transceiver	1	
Mounting kit	1	see table 1.4
Kit of tools and accessories	1	see table 1.5
User manual	1	
Passport	1	
Package	1	

ZEBRA-24.60.BT		
Transceiver	1	
Mounting kit	1	see table 1.4
Kit of tools and accessories	1	see table 1.5
User manual	1	
Passport	1	
Package	1	

1.3.3 Table 1.4 contains information about mounting kits.

Table 1.4 – Mounting kits

Name	Q-ty	Note
1	2	3
1 Mounting kit:		
1.1 Bracket	1	
1.2 Bushing	1	
1.3 Protective visor	1	
1.4 Bolt M6×35.36.019 GOST 7805-70	1	
1.5 Washer 6.01.0115 GOST 10450-78	1	
1.6 Drivescrew 3,9x19 DIN 7981 galvanized	2	
1.7 Conduit adapter for corrugated tube	1	
1.8 Corrugated tube PA 601013 F0	1	L=0,75m
1.9 Buckle 70-90	2	

1.3.4 Table 1.5 contains information about kit of tools and accessories.

Table 1.5 – Kit of tools and accessories

Name	Q-ty	Note
1 Kit of tools and accessories:		
1.1 Wrench/open end spanner	1	S10x10
1.2 Cable USB-B M- USB-A M (1.8 m)	1	

Note – When ordering, please note frequency letters.

1.4 Construction and operation

1.4.1 The sensor consists of one unit.

1.4.2 Construction of ZEBRA-24.60.

1.4.2.1 The sensor has (dimensions 211x134x78 mm) a plastic base. On the base there are a microstrip antenna and a signal processing board. The basis is covered with radiotransparent housing. There are two holes in the bottom of the housing to prevent condensation inside the unit. The configuration elements are covered with a lid. The sensor is connected using a nine-core-cable taken out through the cable gland.

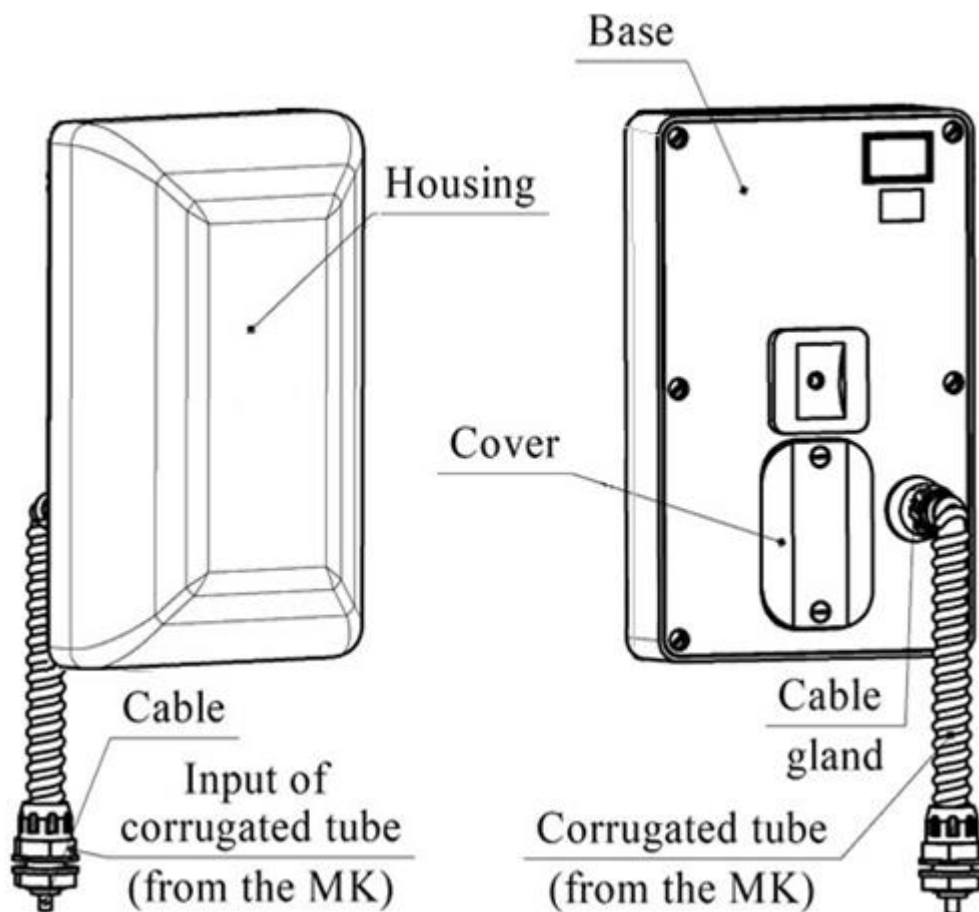

Note – The appearance of the cable gland and conduit adapter for the corrugated tube may differ from ones shown on the picture.

Figure 1.2 – Construction of ZEBRA-24.60

1.4.3 Configuration elements of ZEBRA-24.60.

1.4.3.1 Figure 1.3 shows the configuration elements located under the lid.

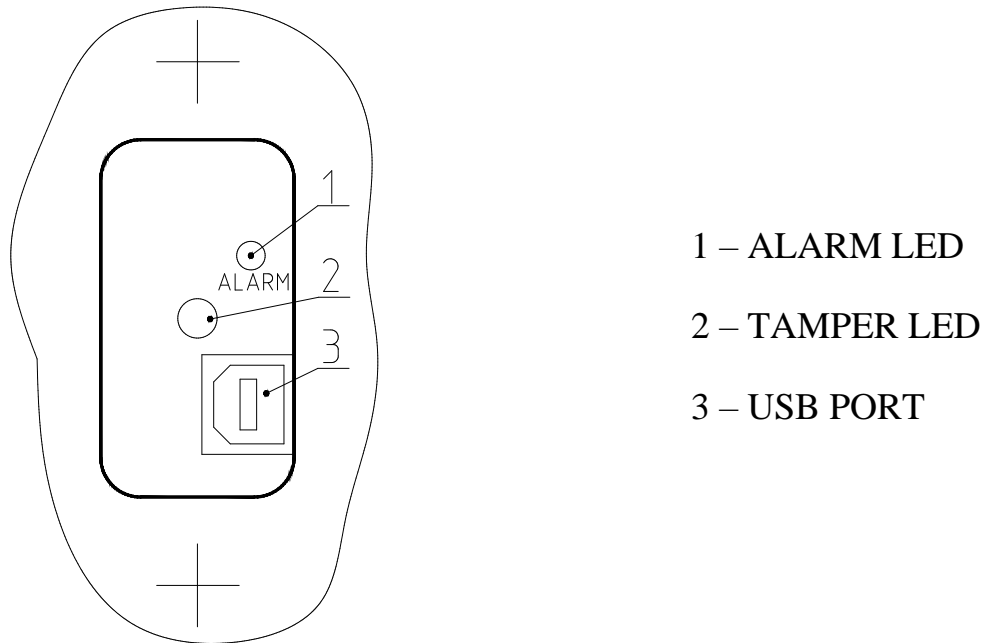

Figure 1.3 – Configuration elements of ZEBRA-24.60

1.4.3.2 Mode indication:

- In the mode ALARM the LED is ON within 3 seconds
- In the mode OPERATION the LED is OFF.

1.4.3.3 To prevent sabotage there is a tamper button under the lid of the sensor. When opening the lid, the alarm signal is generated via RS-485.

1.4.3.4 The sensor can be configured, controlled and indicate its operation in the following ways:

- When using Windows based computers by means of controls in the dialog window of the software Config ZEBRA Sensors
- When using Android based devices by means of controls in the dialog window of the software ZEBRA UNI.

The sensor is connected to the computer via USB slot.

1.4.4 Principle of operation.

1.4.4.1 The principle of operation is based on the linear frequency modulation; it means that the operational frequency of the generator varies linearly within narrow limits. The transmitter radiates microwave energy that is reflected back into the receiver by objects within the detection zone.

1.4.4.2 Changes in the received signal caused by the Doppler Effect, when an object moving in the detection zone, are amplified and processed according to the given algorithm. If these changes exceed the threshold value, the sensor generates an alarm signal.

1.4.4.3 The linear frequency modulation and the division of the detection zone into 12 (twelve) subzones increase the noise immunity and the time until the arrival of the first false alarm.

1.4.5 Operation.

1.4.5.1 After the power has been supplied, the sensor starts monitoring of its performance within 15 seconds.

After the automatic control has been done, the sensor switches to the standby mode.

When triggered, the sensor generates an alarm within 3 seconds and then switches to the normal state within 5 seconds.

1.5 Measuring instruments, tools and accessories

1.5.1 For adjustment and configuration during the sensor operation should be used:

- Notebook on basis of Windows and USB-B – USB-A cable from the kit of instruments and accessories (KIA)
- Tablet on basis of Android, USB-B – USB-A M cable from the kit of instruments and accessories (KIA) and OTG cable (not included into the delivery kit)
- Tablet on basis of Android with the Bluetooth-interface (for modification ZEBRA-24.60.BT)
- Remote computer connected to the sensors via interface RS-485.

1.6 Marking

1.6.1 The sensor marking contains:

- Trademark name
- Sensor name
- Serial number
- Year and quarter of manufacture.

1.6.2 The package marking contains:

- Sensor name
- Name of the trademark
- Address, telephone number (fax), e-mail and website of the supplier
- Power supply voltage range
- Application area
- Application properties (functional specifications)
- Picture of the appearance of the sensor
- Date of packaging
- Manipulation signs and signs of transportation conditions.

2 Intended use

2.1 Use limits

- 2.1.1 The sensors can be used only, if conditions of item 1.1.5 of the present user manual are met.
- 2.1.2 Site requirements should meet requirements of items 1.2.2.1, 1.2.2.2.
- 2.1.3 The input signal level depends on height and weight of a person, his speed of movement, point of crossing the area and relief.
- 2.1.4 The signal at the input of the sensor may be changed influenced by precipitation, small animals, electromagnetic interference, trees and wings of a gate entering the detection zone, with amplitude comparable to the human intrusion.
- 2.1.5 The following factors can affect the input signal: extensive buildings or objects (fences, walls etc.) near the detection zone, uneven terrain, snow or vegetation on the area. If such factors take place, due to reflections and interferences the detection zone is distorted.
- 2.1.6 On objects with the increased lightning statics, it is necessary to use lightning units. The lightning units should be used when the length of connecting lines exceeds 300 m.

2.2 Preparation for use

2.2.1 Safety measures

2.2.1.1 Installation, commissioning and maintenance of the sensor are allowed to persons who have studied the present manual in full.

2.2.1.2 When maintaining the sensor, the safety rules by working with equipment under voltage up to 1000 V should be followed.

2.2.1.3 **IT IS PROHIBITED TO DO INSTALLATION AND COMMISSIONING WORK DURING THE STORM DUE TO THE RISK OF ELECTRICAL SHOCK.**

2.2.1.4 When cabling, terminating and connecting the cable to the sensor, the power supply should be switched OFF.

2.2.1.5 The sensor is powered with 10...30 V DC or with 220 V AC through a power supply unit. Before starting works, please learn the user manual of the power supply unit.

2.2.1.6 Persons who have been specially instructed and have passed a safety test are allowed to install, maintain and repair the sensors.

2.2.2 Rules for unpacking and inspecting the sensor.

2.2.2.1 Before unpacking the sensor, carefully inspect the package and ensure its integrity. Before opening the package, check the presence of the stamp of the quality department.

2.2.2.2 The package should be opened indoors or under a canopy. When unpacking, avoid ingress of precipitation and influence of aggressive substances on the sensor.

2.2.2.3 Check the completeness of the sensor.

2.2.2.4 Check the presence of the quality department stamp in the passport of the sensor.

2.2.2.5 The sensors should be free from defects like deep scratches and dents.

2.3 Installation and configuration

2.3.1 General guidelines

2.3.1.1 The sensors should be installed in accordance with requirements of the present manual and projects recommendations on the alarm system.

2.3.1.2 The sequence of installation works is based on convenience of their execution.

2.3.1.3 The sensors should be installed to provide a convenient supply of connecting cables and free access to them during mounting, operation and maintenance.

2.3.1.4 The sensor wiring and connection to the junction box and power supply unit are to perform in accordance with the project for the alarm system.

ATTENTION!

1. DON'T INSTALL THE SENSORS NEXT TO EACH OTHER, IF THEY HAVE THE SAME FREQUENCY LETTER. When ordering the sensors with different frequency letters, please be guided by the project documentation. When more than five sensors are used on the object, check their applicability by the trial operation.

2. When installing the sensors in ways other than those given in the present manual, check their applicability in trial operation.

2.3.2 Installation order

2.3.2.1 Ensure compliance with requirements of item 2.1.2.

2.3.2.2 Prepare the perimeter to install the posts.

2.3.2.3 Install the posts. As posts it is recommended to use metal pipes with a diameter of 70...90 mm. The height of the post above the ground should be at least 1100 mm. In areas with much snow, the above-ground part of the post should be at least 1500 mm.

2.3.2.4 Installation of posts in concrete is possible. The posts should be made of steel pipe with a diameter of 76 mm and may have a length of 2 m or 2.5 m. The post construction should contain a rebar to hold the post in concrete and holes to enter the cable.

2.3.2.5 The above-ground part of the post should be at least 1100 mm.

Figure 2.1 shows the post installation.

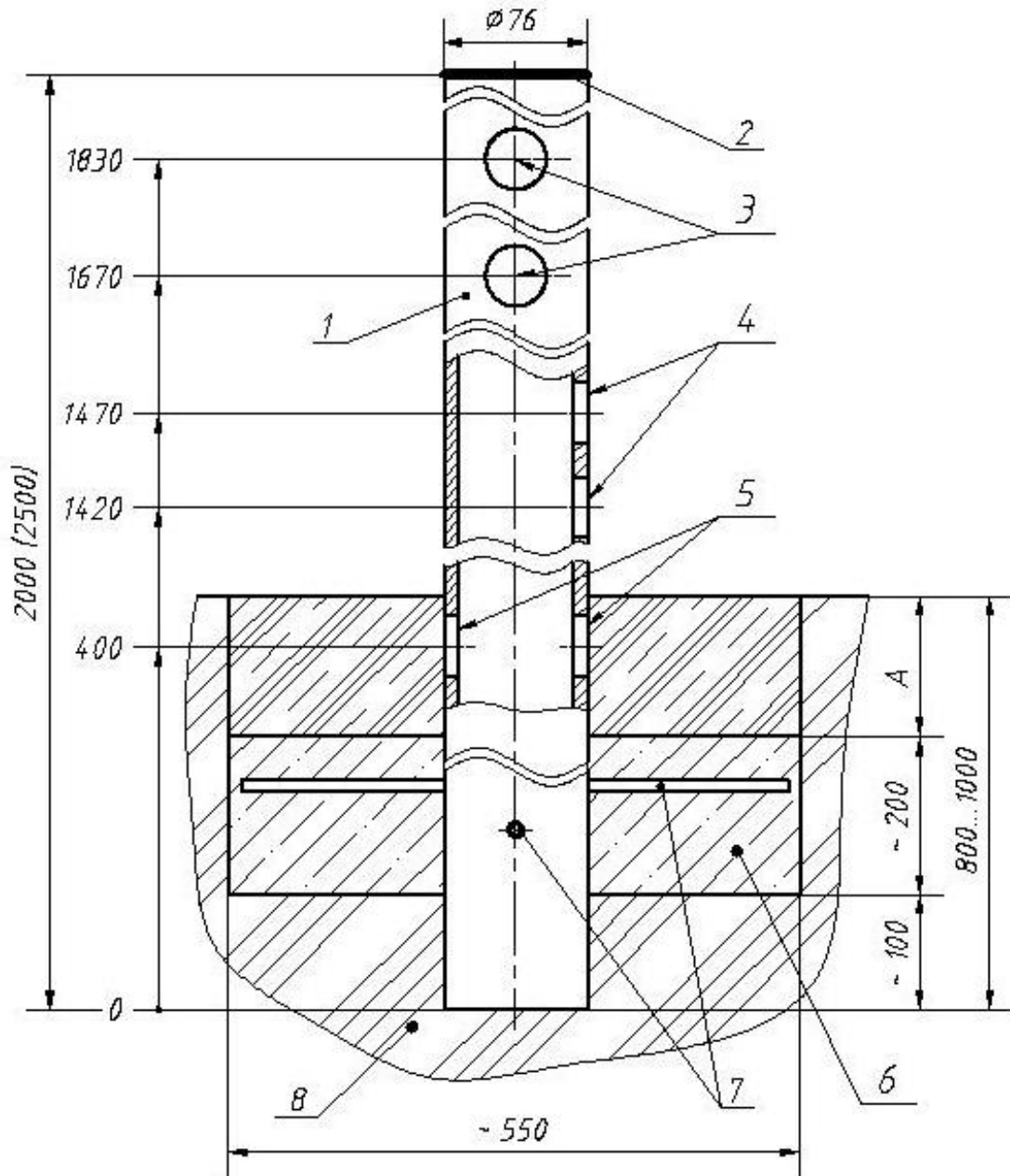

1 - post; 2 - plastic plug; 3 - holes to enter the cable inside the post; 4 - holes to enter the main cable and the sensor cable; 5 - holes to enter the main cable; 6 - concrete (gravel); 7- rebars to prevent an unauthorized demounting; 8 - ground.

Note

1 At size A, lay the ground after the installation.

2 Dimensions are given in mm.

Figure 2.1 – Post installation

2.3.2.6 Lay the main cable in accordance with the project for the alarm system.

The cable core section should be chosen to provide a power supply of at least 9 V for each unit of the sensor.

Don't lay the main cables near the sources of strong electromagnetic interferences like power cables, antenna systems etc. and don't use the free cores to transmit impulse signals.

2.3.2.7 If the project includes the application of junction boxes and power supply units, they should be mounted on the same post together with sensor units inside the perimeter.

2.3.3 Mounting on posts.

2.3.3.1 Using two buckles pos.12 (from the mounting kit), mount the sensor pos. 4 on the post pos. 1 (when mounting outdoor pre-install a visor pos. 7 from the mounting kit using two 3,9x19 self-tapping screws supplied) as shown on Figure 2.2. For mounting on a post of a larger diameter, use buckles 12 mm wide (are not included in to the delivery kit).

In the absence of snow cover the mounting height should meet the height given on Figure 2.2.

ATTENTION! THE SENSOR ON THE POLE SHOULD BE DIRECTED WITH DRAINAGE HOLES DOWN!

2.3.3.2 Thread the cable of the sensor through the corrugated tube pos. 5 (from the mounting kit). Put the input pos. 6 (from the mounting kit) on the corrugated tube.

IMPORTANT! THE CORRUGATED TUBE IS OBLIGATORY TO PUT.

2.3.4 Mounting on brackets.

2.3.4.1 If the posts can't be installed and there is a rigid fence, so it is recommended to mount ZEBRA-24.60 on brackets 1000 or 1250 mm long. Such brackets can be used for mounting sensors and junction boxes on the fence or to the wall.

2.3.4.2 Mount the sensors on brackets following item 2.3.3.

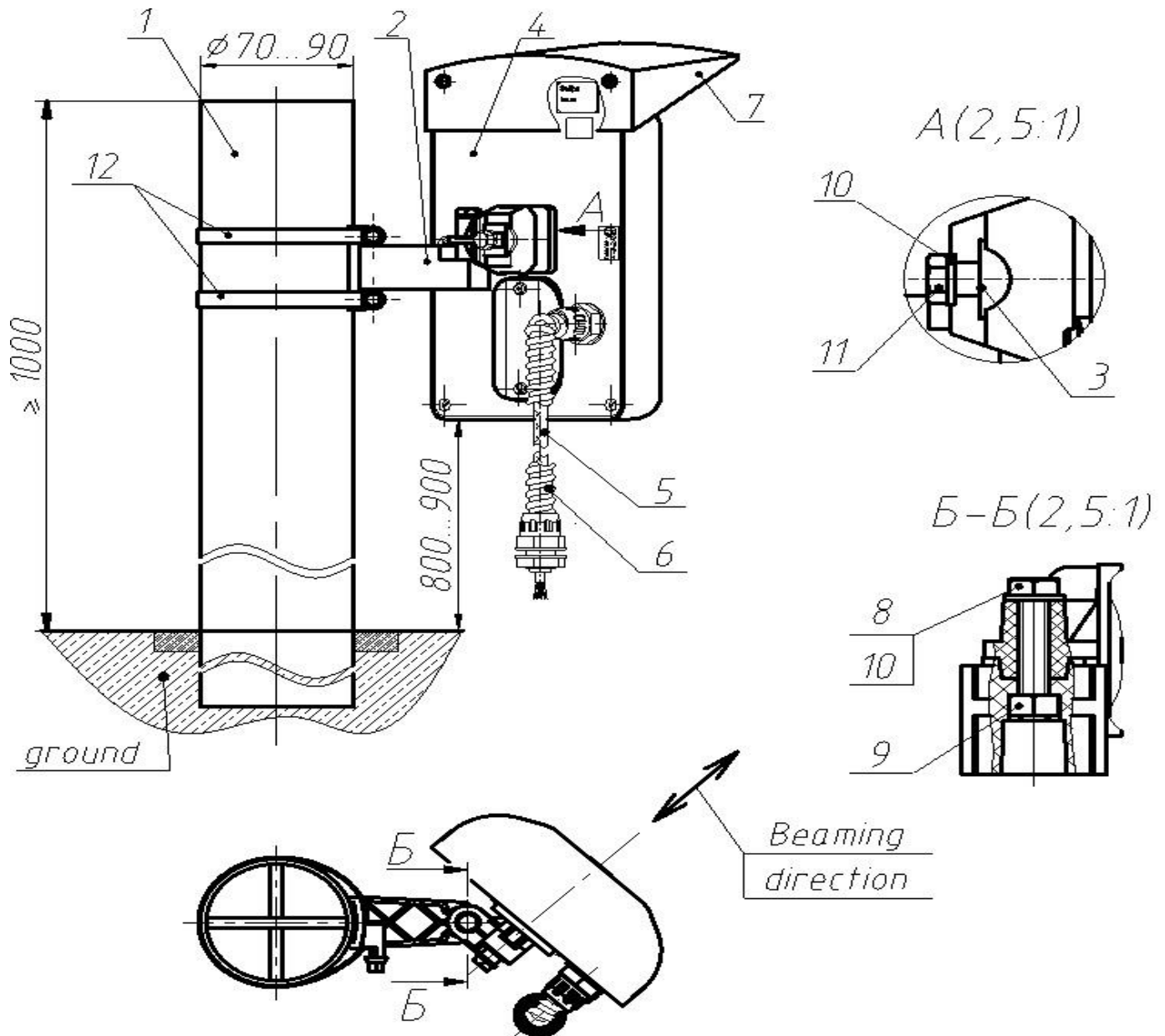

1 – Post	- 1 pc.	7 - Visor	- 1 pc.
2 - Bracket	- 1 pc.	8 - Bolt M6x35	- 1 pc.
3 - Bushing	- 1 pc.	9 - Nut M6	- 1 pc.
4 - Transceiver unit	- 1 pc.	10 - Washer 6	- 2 pcs.
5 - Corrugated tube	- 1 pc.	11 - Bolt M6x35	- 1 pc.
6 - Input for corrugated hose	- 2 pcs	12 - Buckle	- 2 pcs

Note:

1. Mounting on the post using a protective visor (from the mounting kit). Visor pos. 7 is to mount by outdoor installation.
2. Dimensions are in mm.

Figure 2.2 – Mounting on the post

-
- 2.3.5 Installation order of ZEBRA-24.60 on the protected surface.
- 2.3.5.1 Depending on the application task, the sensors ZEBRA-24.60 can be mounted on brackets with overhang of 500, 350 and 120 mm:
- 500 mm bracket is recommended, if the top of the fence is protected with physical protection means (reinforced twisted barbed tape, razor wire etc.) (see figures 2.3, 2.5)
 - 350 mm bracket is recommended, if on the top of the fence there are no physical protection means (see figures 2.3, 2.5)
 - 120 mm bracket is recommended, if the radiation direction is perpendicularly to the supporting surface or within an angle ($90^\circ \pm 40^\circ$) (see figures 2.4, 2.5).
- 2.3.5.2 At the selected site mark out the area in accordance with figures 2.3, 2.4.
- 2.3.5.3 Fix on the wall pos. 1 the bracket pos. 2 using screws pos. 6.
- 2.3.5.4 Insert the bolt pos. 11 in the slot of ring pos. 8 and fasten the transceiver unit on bracket pos. 2.
- 2.3.5.5 Loosen the nut pos. 9 and point the unit on the necessary direction turning it in a horizontal surface.
- 2.3.5.6 Tighten the nut pos. 9.
- 2.3.5.7 Moving the transceiver in a vertical surface relative to the ring slot pos. 8, align the unit in a vertical surface and tighten it with the bolt pos. 11.

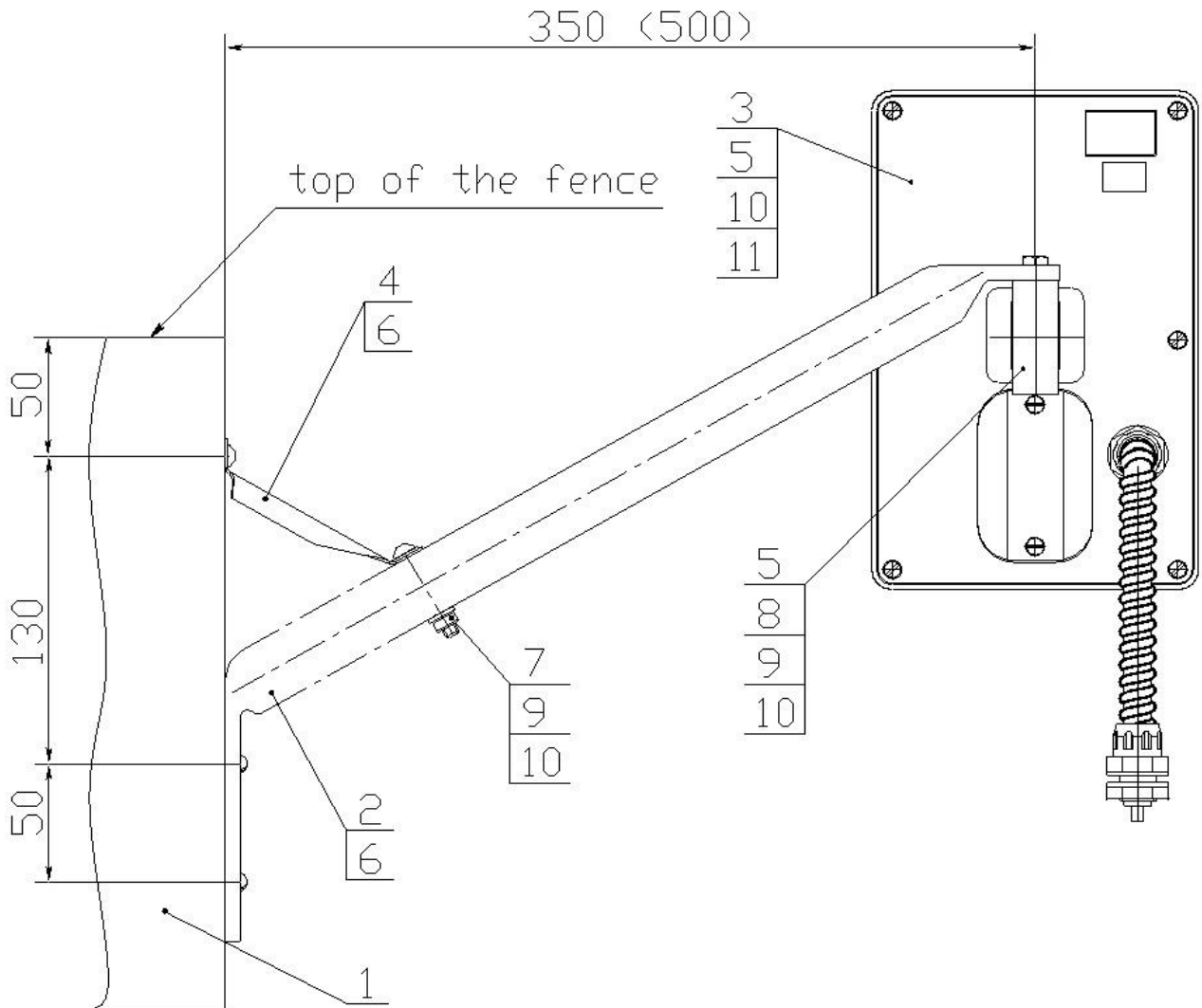

1 - fence		7 - bolt M6x35	- 1 pc.;
2 - bracket	- 1 pc.;	8 - ring	- 1 pc.;
3 - transceiver unit	- 1 pc.;	9 - nut M6	- 2 pcs.;
4 - angle	- 1 pc.;	10 - washer 6	- 4 pcs.;
5 - figured washer	- 2 pcs.;	11 - bolt M6x14	- 1 pc.
6 - screw M6x50	- 4 pcs.;		

Figure 2.3 – Mounting on bracket 500 mm (350 mm)

Note:

1. Mounting on the surface without protective visor.
2. Dimensions are in mm.

ATTENTION! INSTALL BRACKETS 350 OR 500 ON THE TOP OF THE FENCE FOR PROTECTION AGAINST OVERCLIMBING (SEE FIGURE 2.3)

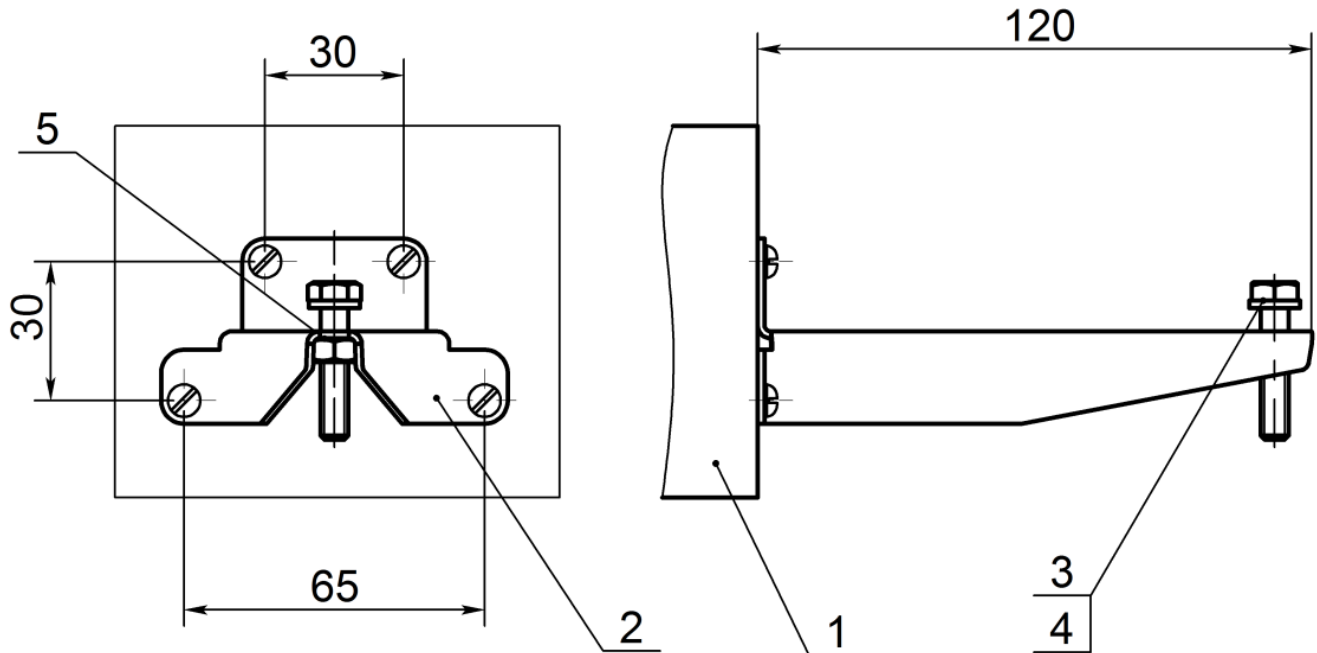

- | | | | |
|----------------|----------|--------------|----------|
| 1 - Fence; | | 4 - Washer 6 | - 1 pc.; |
| 2 - Bracket | - 1 pc.; | 5 - Nut M6 | - 1 pc. |
| 3 - Bolt M6×30 | - 1 pc.; | | |

Figure 2.4 – Mounting of bracket 120 mm

2.3.5.8 Figure 2.5 shows mounting of the sensor using brackets 500, 350 120 mm

2.3.5.9 Rotation angle of the transceiver on the bracket:

- In the horizontal plane - 180°
- In the vertical plane: up – through angle 17°, down – through angle 45°.

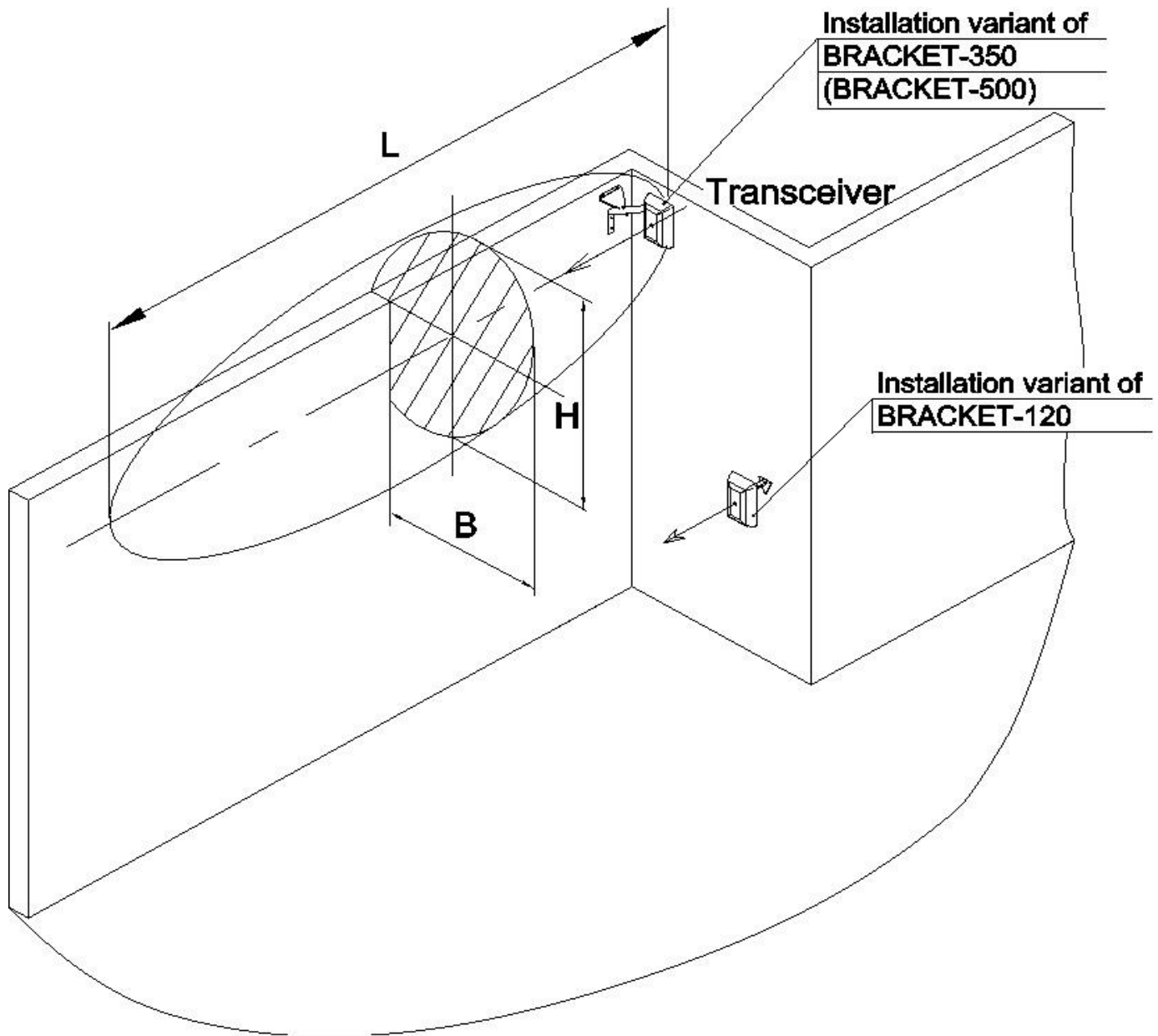

Figure 2.5 – Mounting on brackets 500, 350, 120 mm

Note:

- 1 When installing transceivers along the walls and other extended surfaces, brackets with minimum overhang of 350 mm should be used because of absorption and reflections from the wall the technical characteristics can be deteriorated.
- 2 The size and material of the fence is not standardized.
- 3 The fence should be rigid.

2.3.6 Connections of the sensor

2.3.6.1 Connect power, signal and remote control circuits in accordance with the project for the alarm system. The transceiver unit is to connect with its own cable. The purpose of the conductor is determined by its colour. Colour and purpose of wires shown in table 2.1.

ATTENTION! IT IS STRICTLY PROHIBITED TO GROUND SENSOR'S CIRCUITS DIRECTLY. IT IS NECESSARY TO USE A LIGHTNING GUARD UNIT (LGU).

Table 2.1 – Purpose of wires

Colour of wires	Purpose	Note
White	Supply plus (+)	
Brown	Supply minus (-)	
Yellow	Relay contacts (NC)	
Pink		
Purple	Tamper circuit (TAMPER)	
Black		
Green	Remote control (RC)	
Blue	RS-485 «B»	
Red	RS-485 «A»	
Grey	Bluetooth activation	For sensor ZEBRA-24.60.BT only

2.3.6.2 The tamper button contacts can be connected with a control panel in two ways:

- As a separate loop, in this case the customer will receive a tamper alarm as a separate signal. The alarm will be received when the cover of the transceiver unit is opened, even when the power supply is off;
- Series connection of tamper button contacts with relay contacts. In this case alarms will be transmitted to one control panel by the relay actuation or opening the cover of the transceiver unit.

2.3.6.3 **To activate the Bluetooth interface on ZEBRA-24.60.BT, connect the grey wire of the transceiver unit to “+” supply.**

2.3.6.4 Figure 2.6 shows the connection diagram using the lightning guard unit (LGU)

To maintain the product warranty, it is recommended to use lightning guard units.

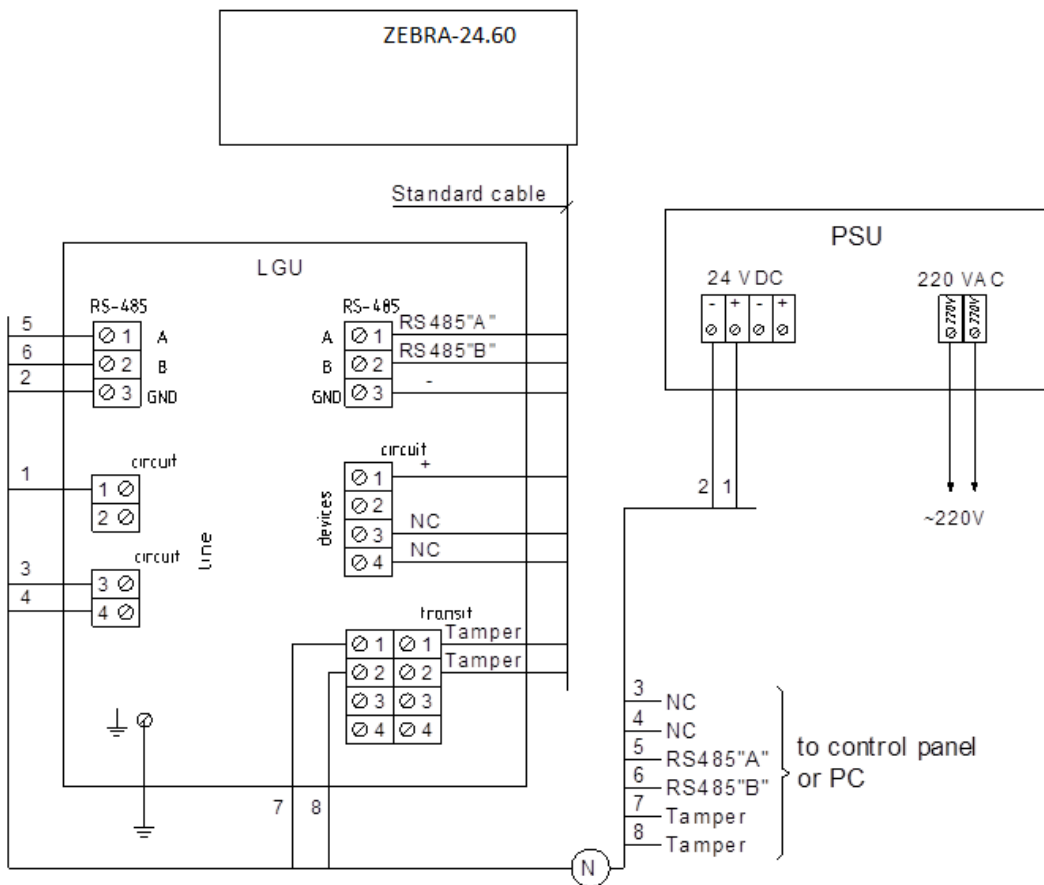

Figure 2.6 – Connection diagram using LGU

2.3.7 Configuration using a notebook (computer) on the Windows platform

2.3.7.1 Before start operating:

- Install the software *Config Zebra Sensors* on the notebook. The software is available on the website www.security-sensor.com
- Install a virtual COM-port driver on the notebook.

2.3.7.1.1 Installation of the managing software *Config Zebra Sensors*.

2.3.7.1.1.1 Start the file *Config Zebra Sensors_install_v2.04* on the computer.

2.3.7.1.1.2 After the file has been started, it will appear the following window.

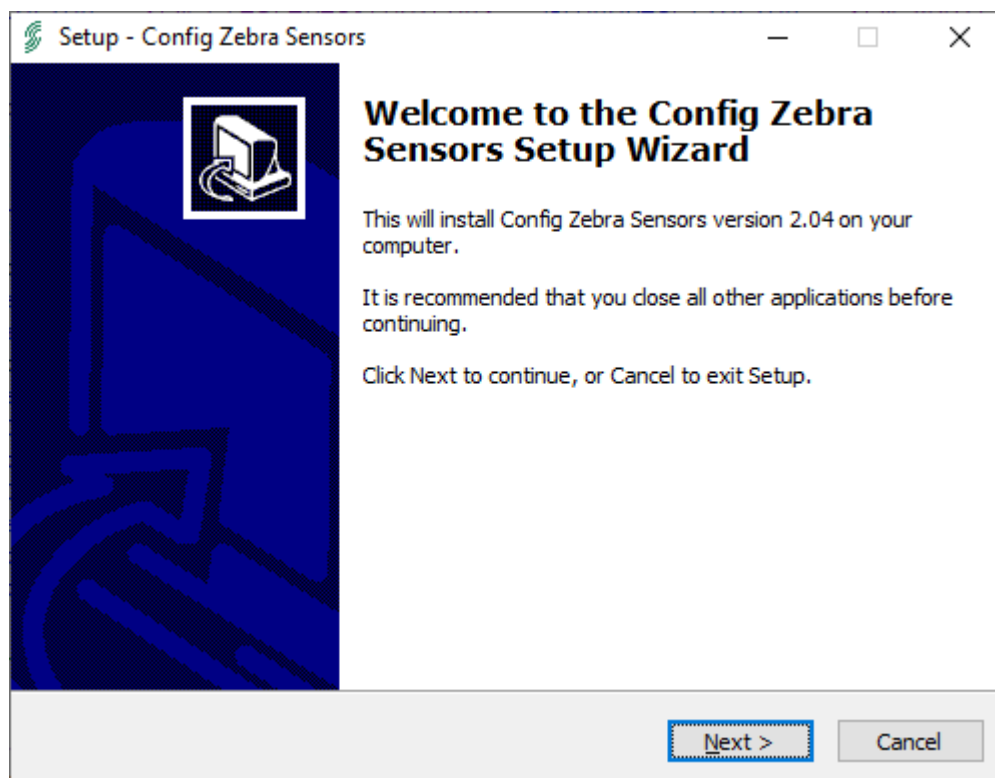

Figure 2.7

To install the program follow the instructions of the installer shown in Figures 2.8-2.11.

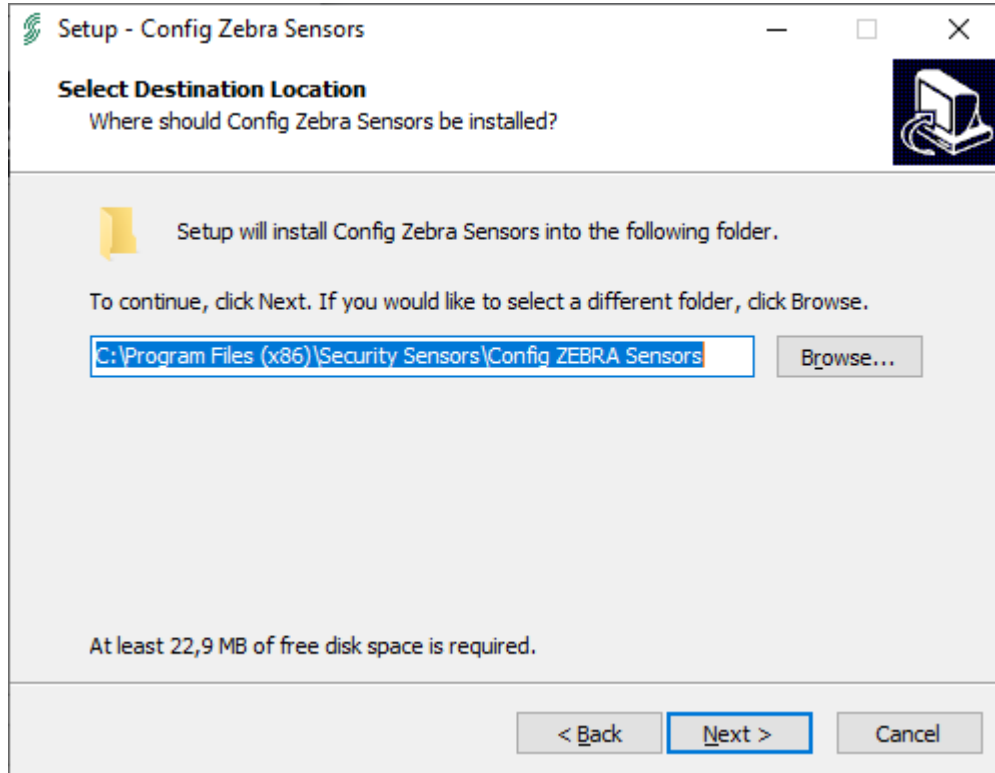

Figure 2.8

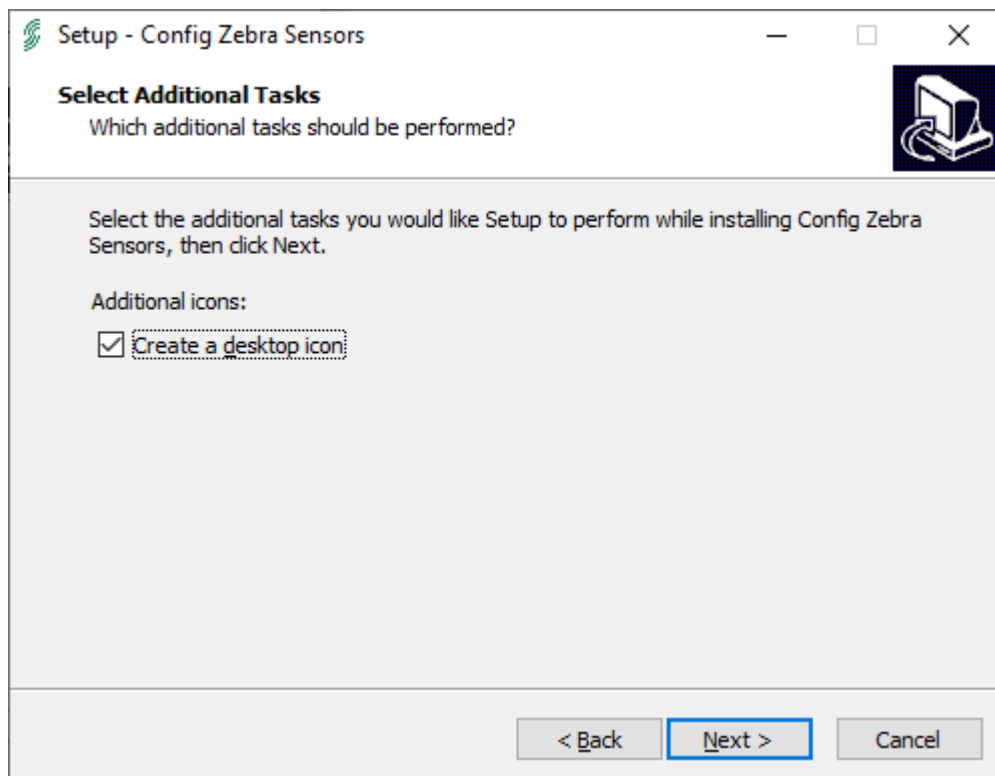

Figure 2.9

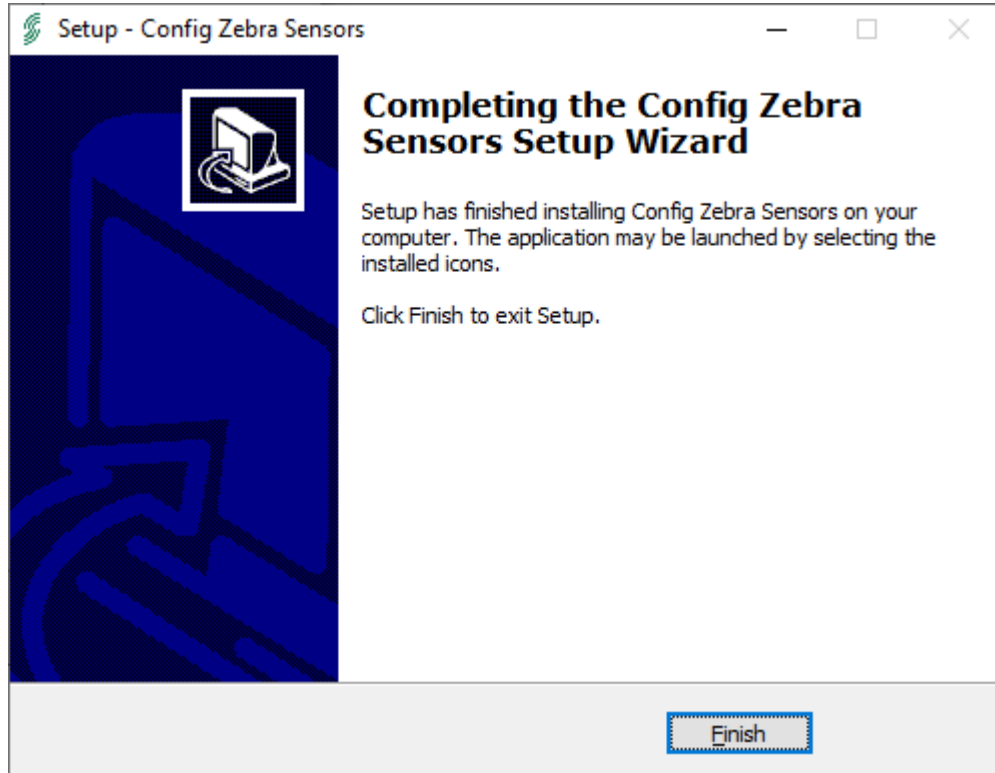

Figure 2.10

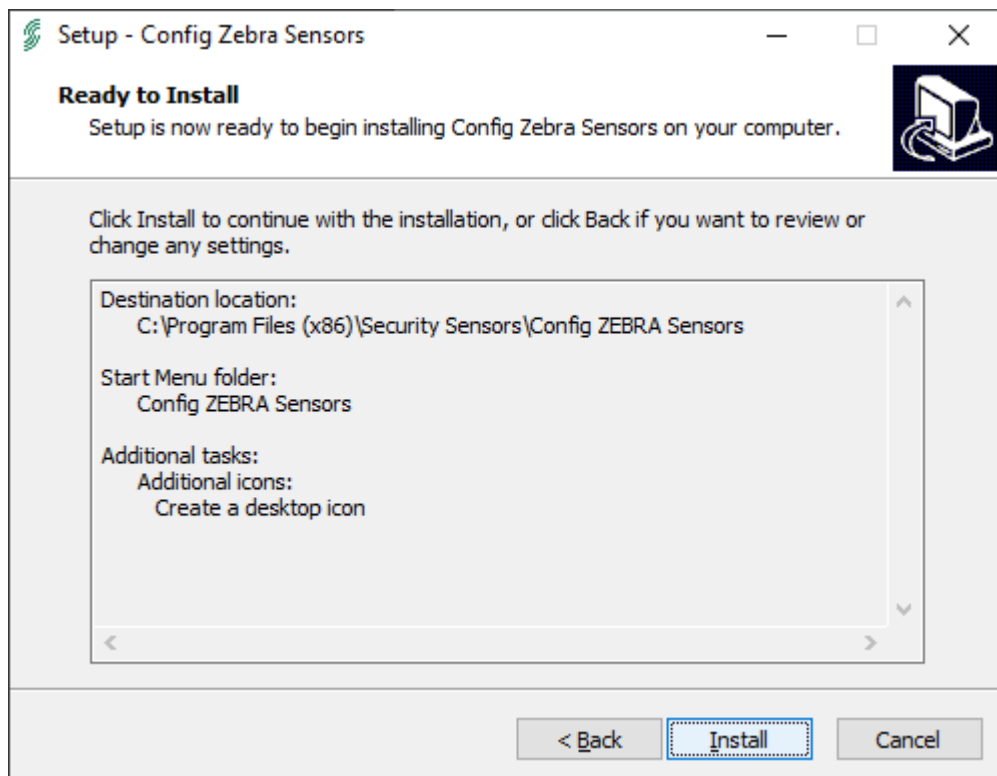

Figure 2.11

- 2.3.7.1.2 Installing the Virtual COM Port Driver.
- 2.3.7.1.2.1 Remove the cover from the configuration elements of the transceiver unit.
- 2.3.7.1.2.2 Connect the notebook via the cable USB A-B (from kit of instruments and accessories) to the USB-slot on the transceiver unit.
- 2.3.7.1.2.3 Apply power to the sensor. The computer will identify the type of the USB device and will ask you to install the driver following actions in accordance with Figures 2.11-2.15.



Figure 2.12

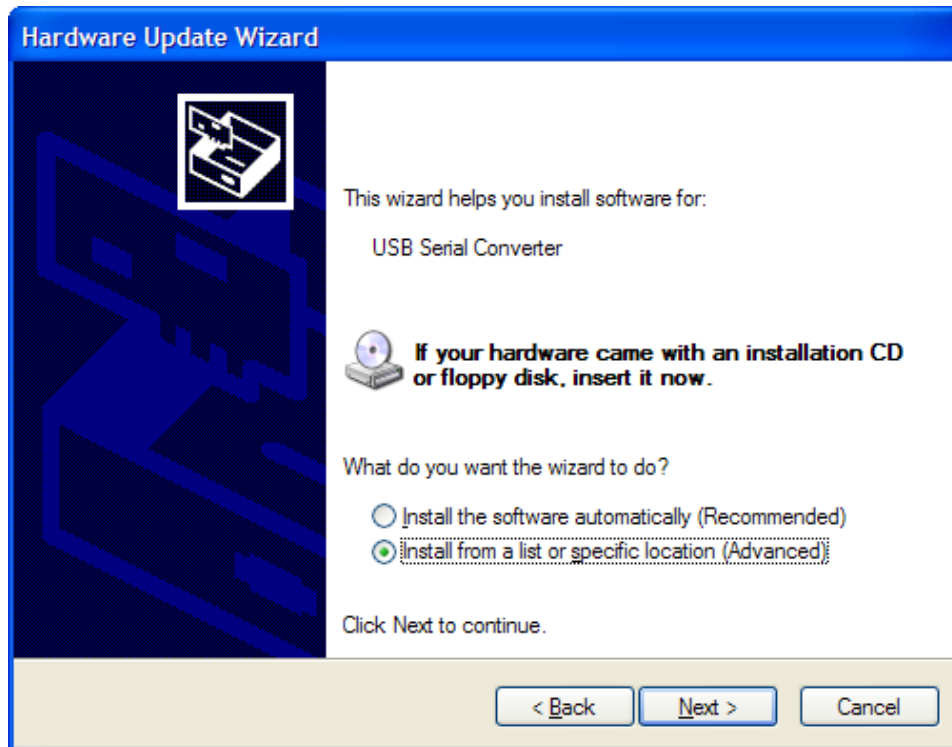

Figure 2.13

Choose the folder COM-PORT in window of Search and Installation Options.

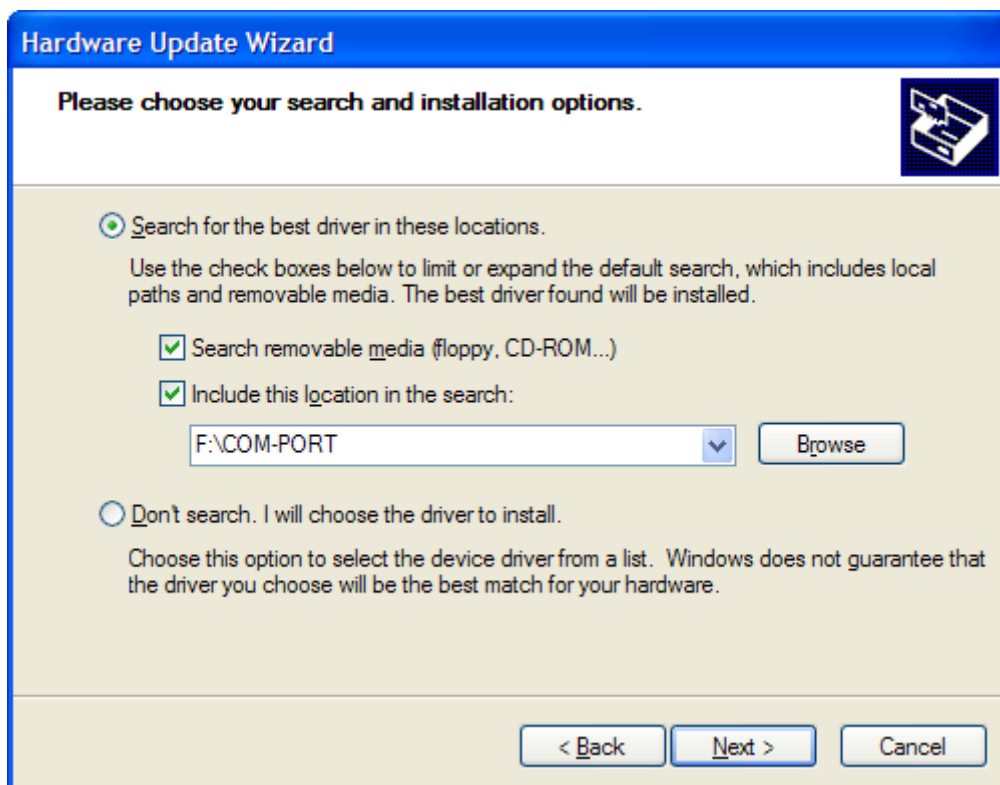

Figure 2.14

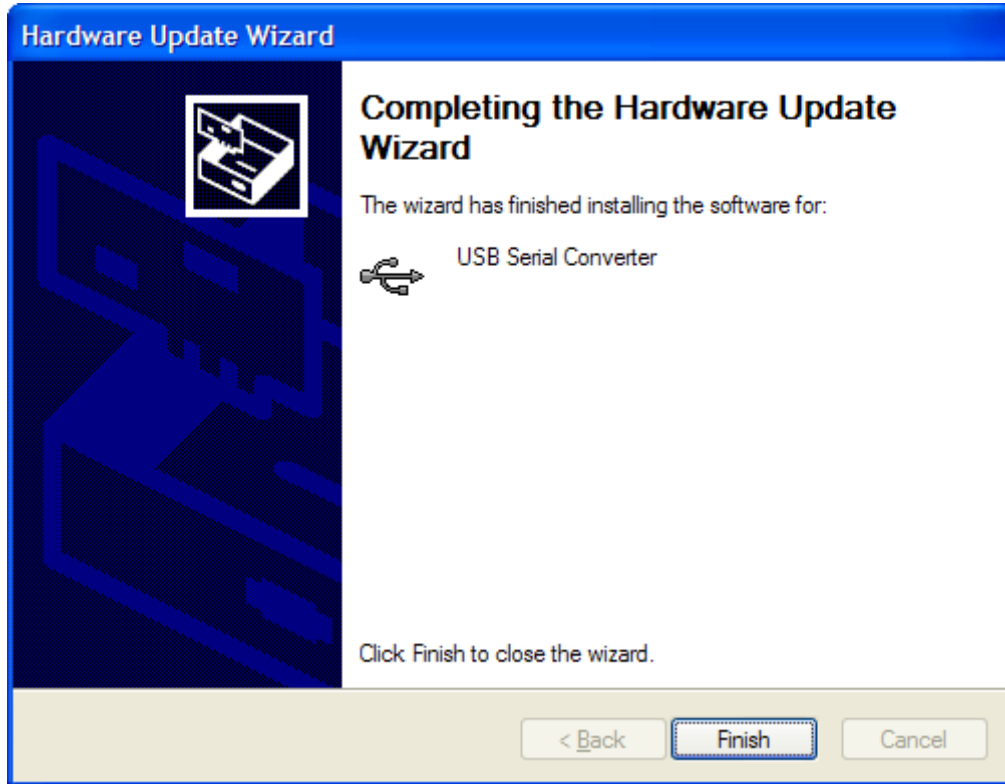

Figure 2.15

Click Finish and the sensor is ready for use.

- 2.3.7.1.2.4 After the virtual COM-PORT driver has been installed, it is necessary to know its number. Please follow: DEVICES MANAGER→PORTS (COM and LPT) →USB SERIAL PORT and remember the number.

2.3.7.2 Configuration

2.3.7.2.1 Start the program *Config Zebra Sensors* from the desktop. After the program has been started, it will appear the window of the search type shown in Figure 2.16.

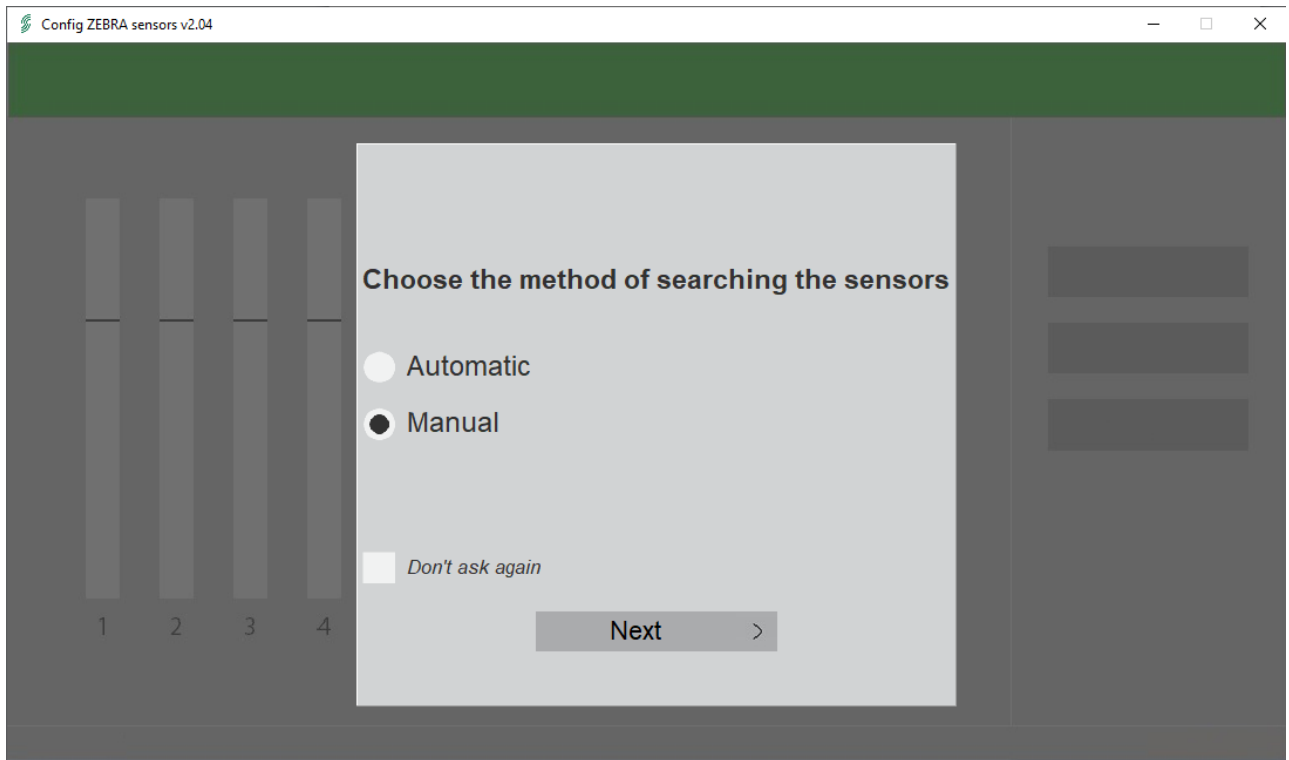

Figure 2.16

If the “Manual search” is chosen, the window shown in Figure 2.17 will be displayed, where you should specify the COM port number, network address by yourself and click the “Search” button.

If the search is successful, an inscription in green will appear showing a sensor (sensors) is found. Upon detection of several sensors, choose an appropriate one and click Standby Mode.

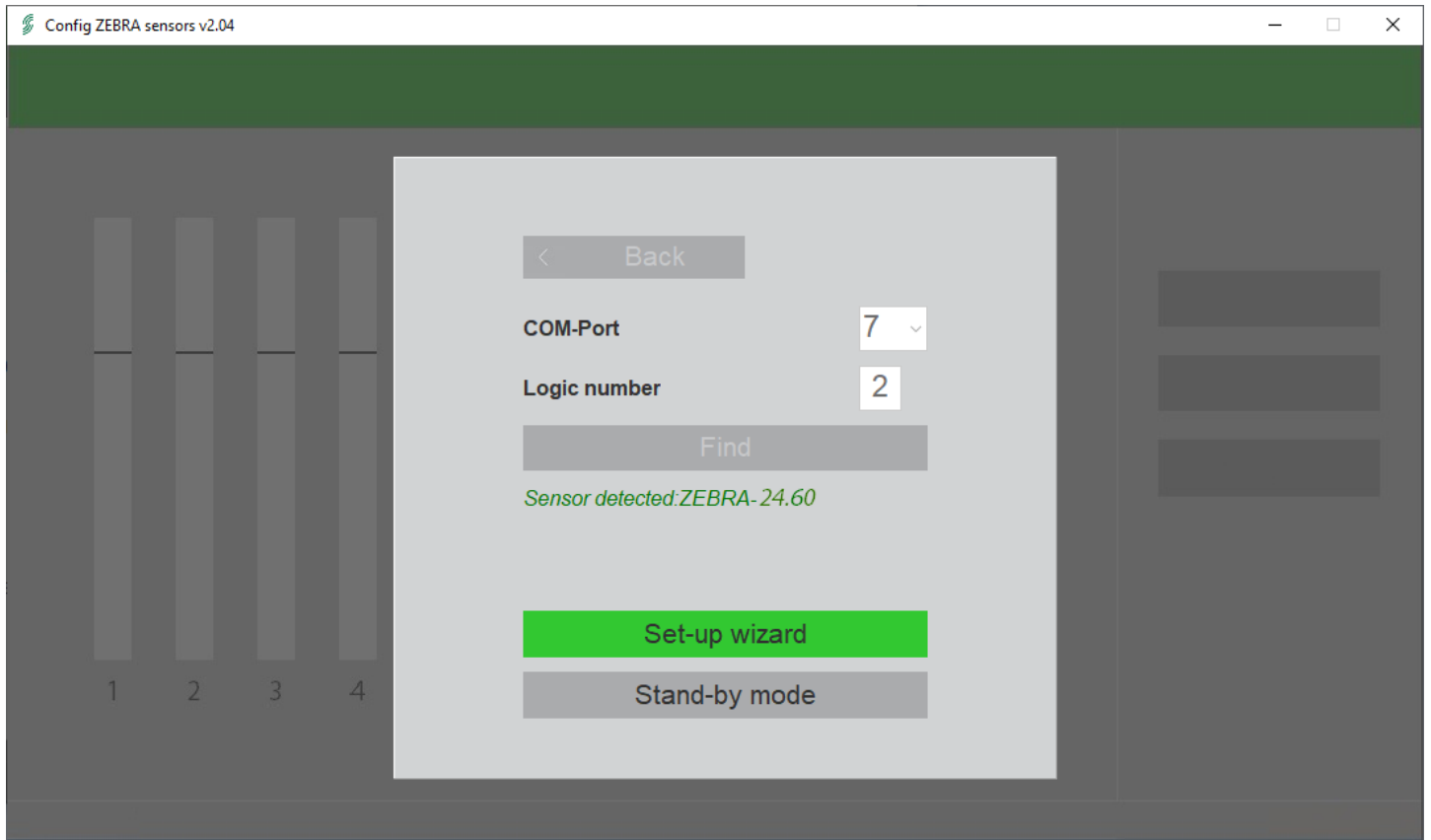

Figure 2.17

If the “Automatic search” is chosen, the search starts immediately (Figure 2.18).

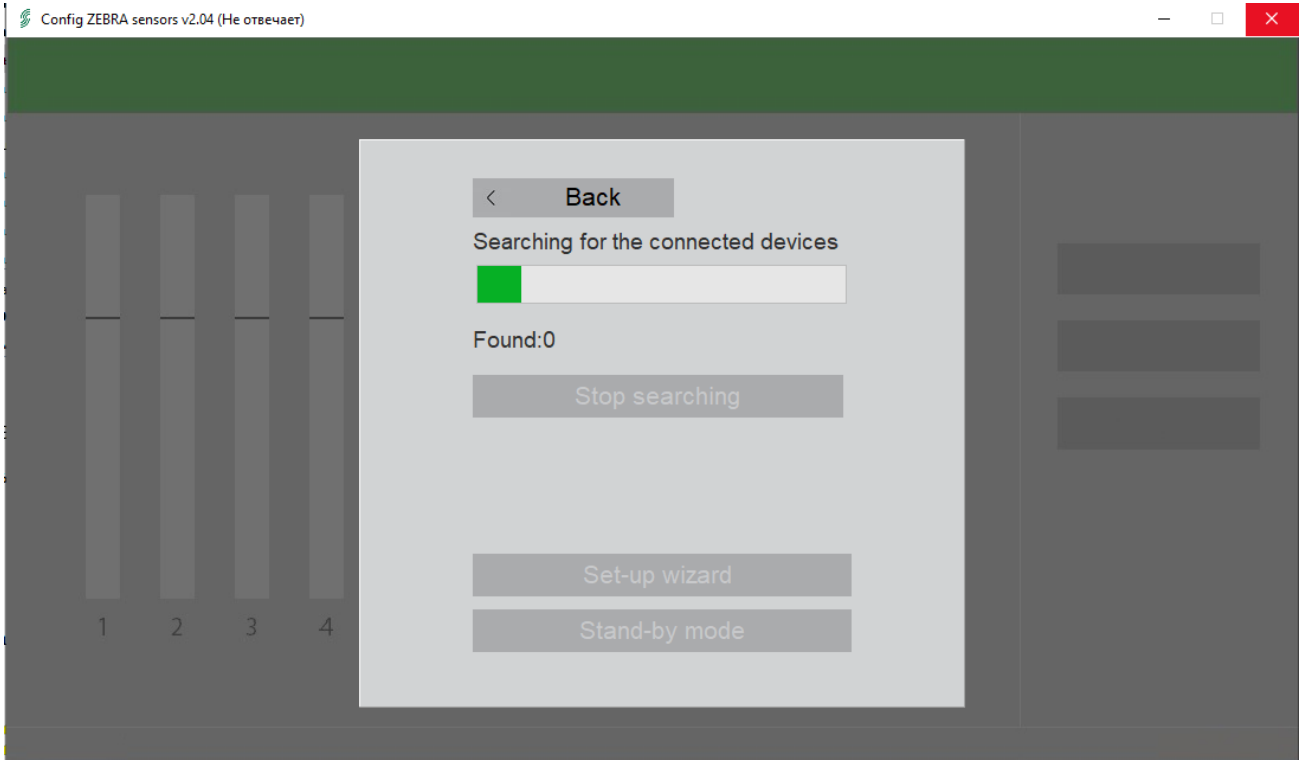

Figure 2.18

If the search failed, check the power supply and connection to the computer.

If the sensor is found, the data exchange between sensor and computer begins automatically (Figure 2.19).

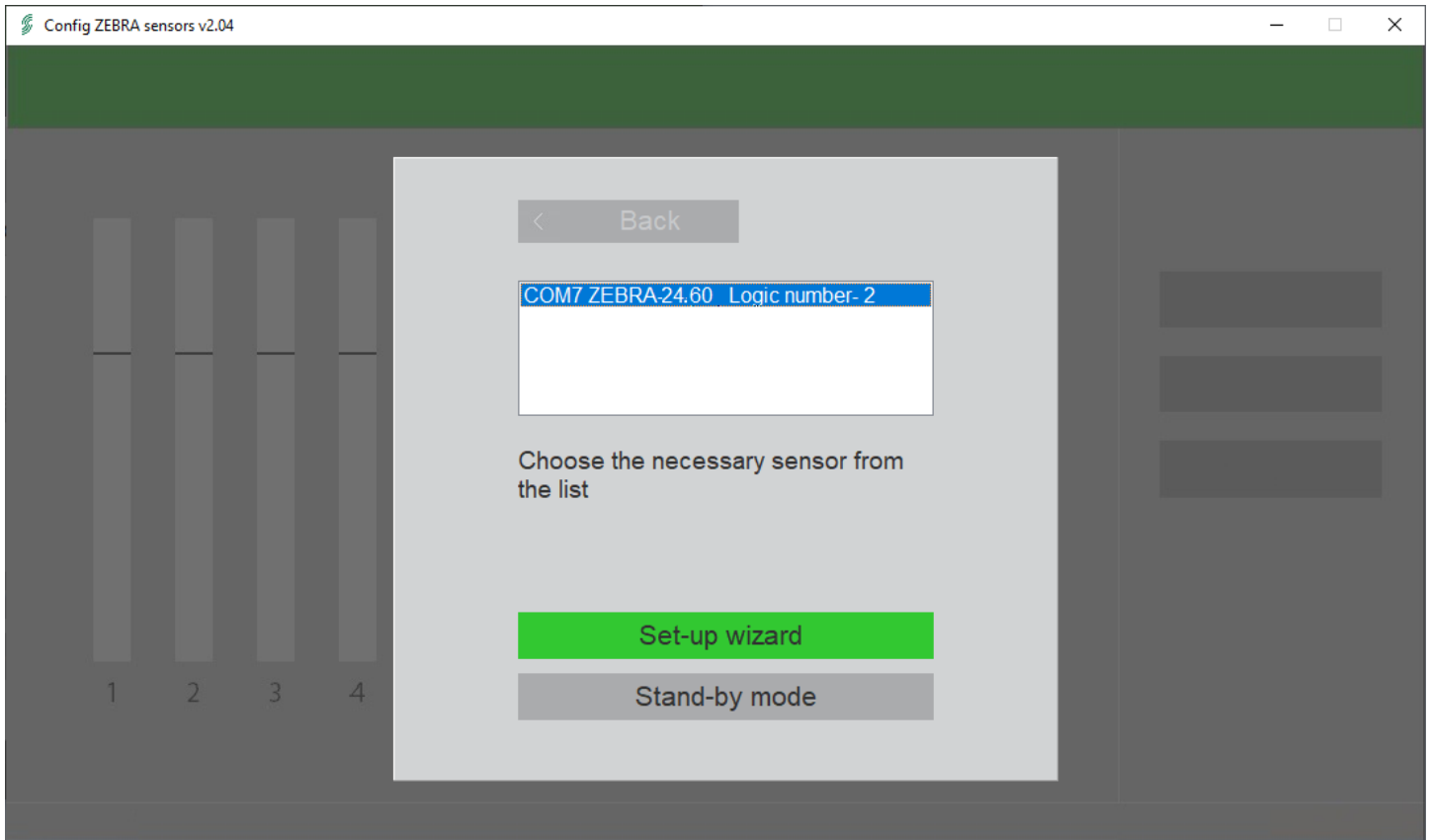

Figure 2.19

Choose the sensor and click Standby Mode.

The program window will be displayed like shown in Figure 2.20

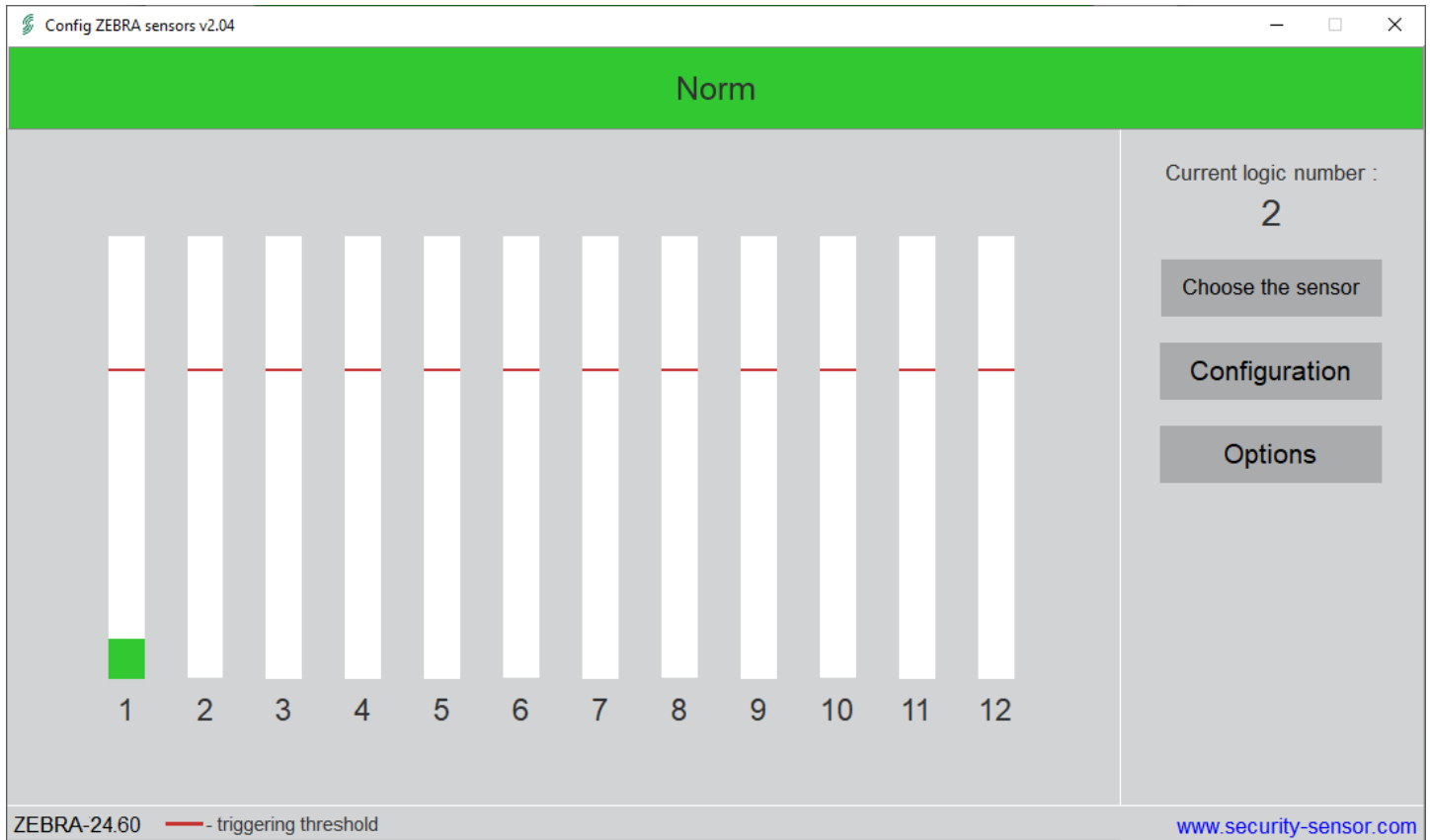

Figure 2.20

- 2.3.7.2.2 Level of signals and interferences of each subzone are displayed in the window of the program, which allows controlling the sensor during operation visually. The signal level is displayed by a column of green color changing in height, when the threshold exceeds, the signal bar turns red. If the subzone is off, the signal bar turns grey. The threshold is indicated by a red line on the columns of the subzones (set up at the factory and not changeable).
- 2.3.7.2.3 The field “Logical number” is used to display the logical number of the sensor. The “Choose the sensor” button is used to choose a sensor, if some sensors are connected. By clicking the “Options” button the window will be displayed like shown in Figure 2.21. In this window you can choose baud rate, switch on/off alarm

signal, language of the user interface and the search method for sensors (by switching on/off the search method of sensors, the previous one will be active). By clicking the “Configuration” button the sensors enters the appropriate mode (item 2.3.7.2.4).

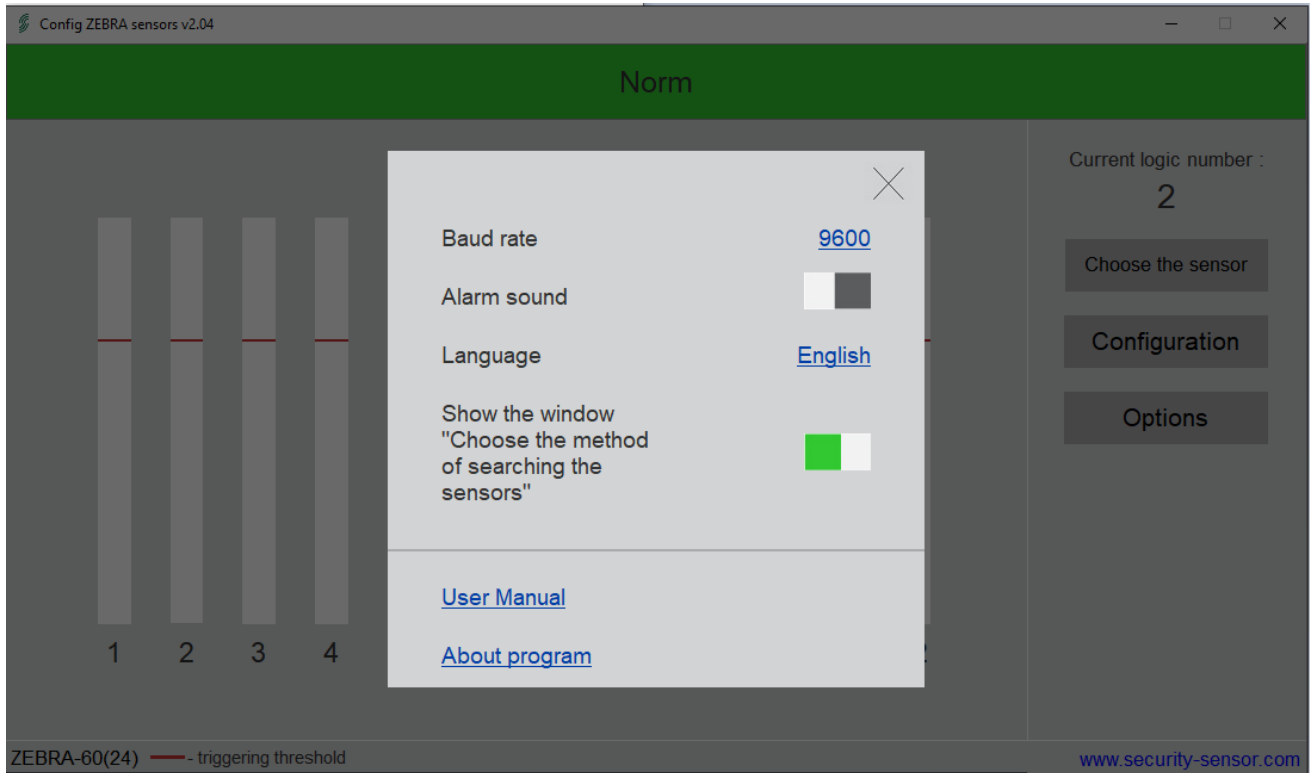

Figure 2.21

2.3.7.2.4 The program window in the mode “Configuration” looks like shown in Figure 2.22.

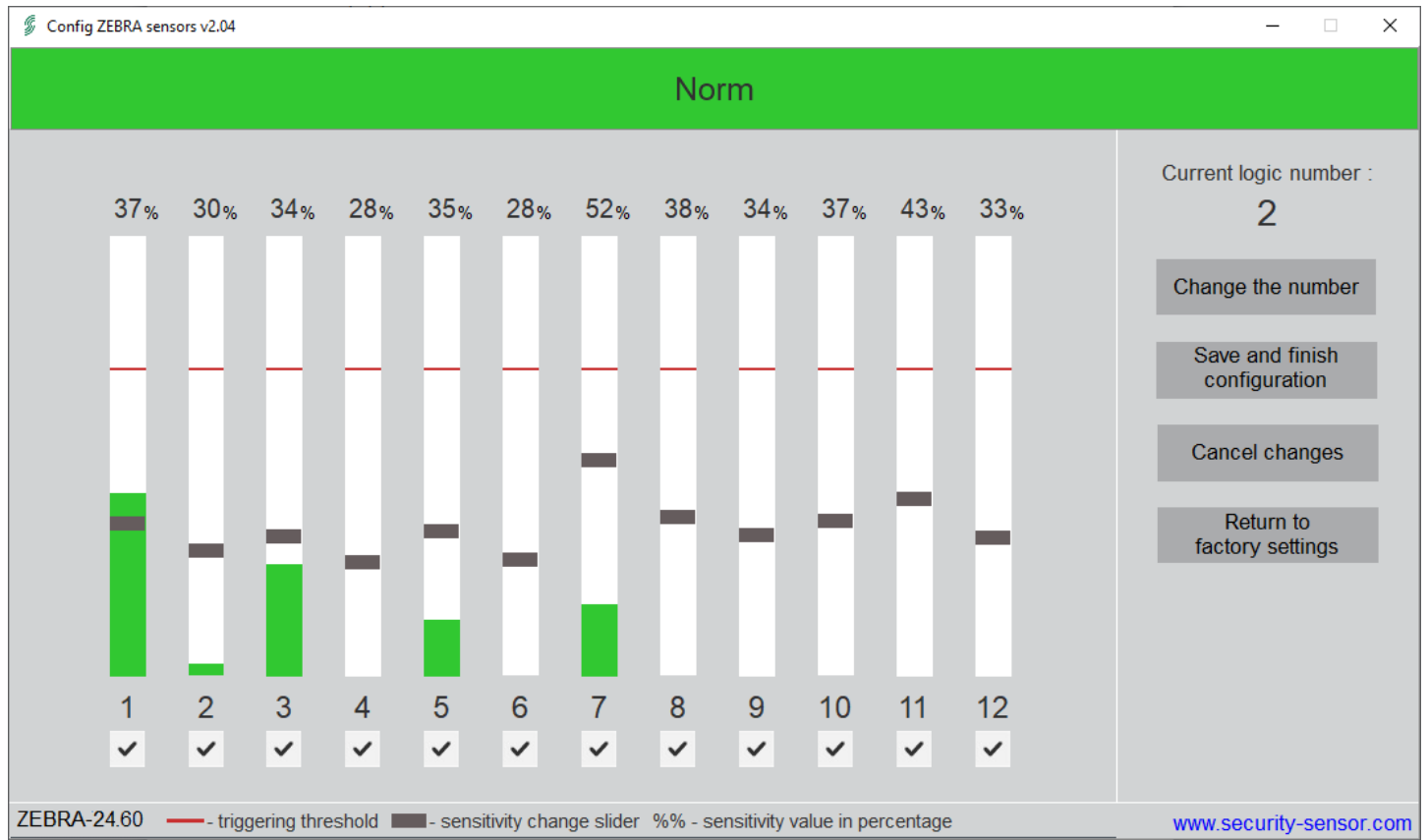

Figure 2.22

2.3.7.2.5 The factory settings of sensitivity are 50% of the column height.

2.3.7.2.6 The button “Save and finish configuration” saves all changes in the permanent memory and puts the sensor into standby mode. The button “Cancel changes” cancels changes made before and puts the sensor into standby mode. The button “Return to factory settings” is used to reset all settings made by the user and restore the factory settings.

The logical number (sensor address) can be changed by clicking on the “Change the number” button. The window shown in figure 2.23 will be displayed.

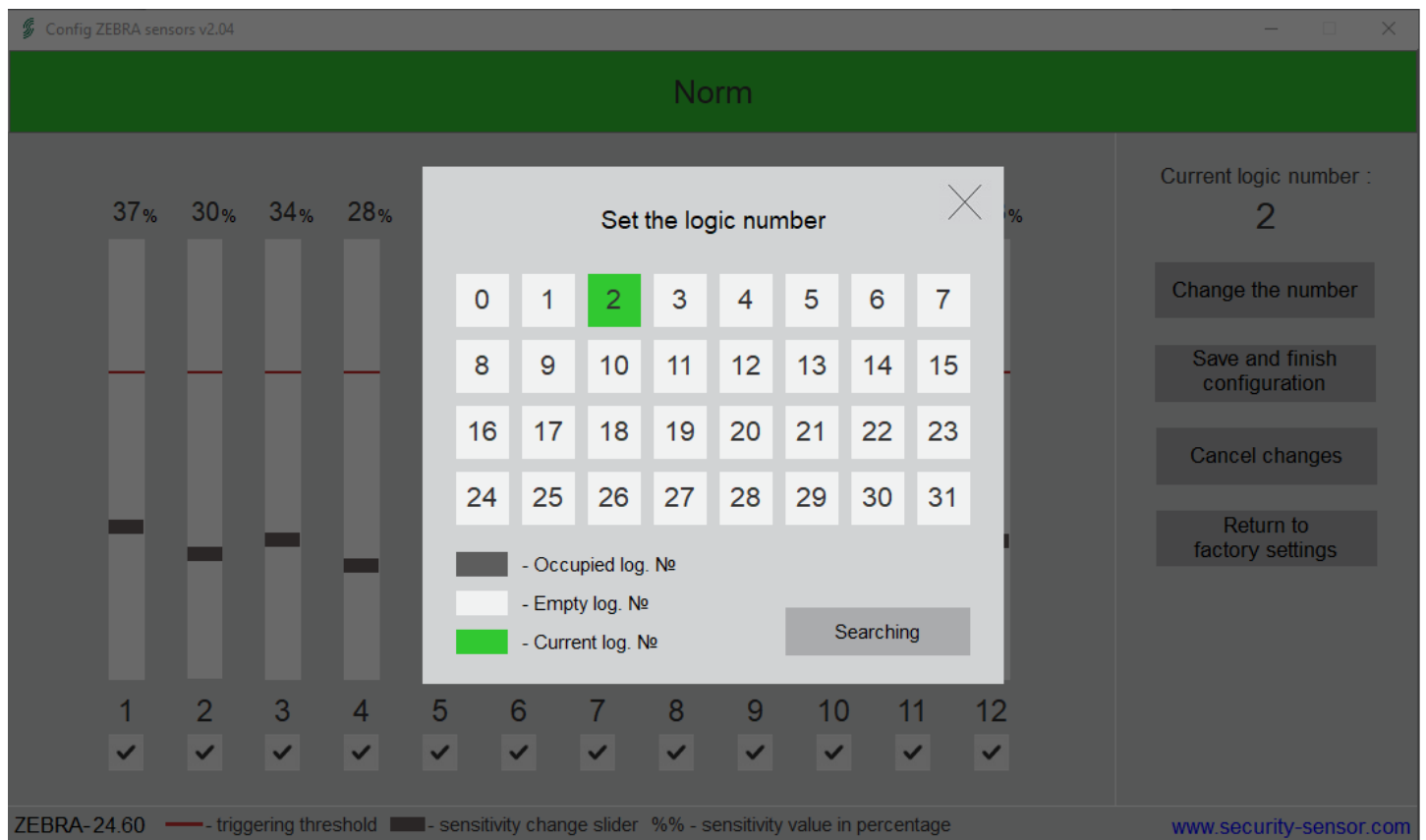

Figure 2.23

When choosing a new logical number, this number is assigned to the sensor. The program automatically starts accessing the sensor, no restart required.

The “Search” button is used to find occupied/free logical numbers, if the manual search was chosen (Figure 2.16). If the automatic search was chosen, the occupied/free logical numbers are determined automatically.

- 2.3.7.2.7 The signal in subzones, when there are no moving objects, indicates interferences (noises). It can be caused in case of non-fulfillment of requirements to the protected area in accordance with items 1.2.2.1, 1.2.2.2. If the level of interferences exceeds 20% of the column height, it may cause nuisance alarms. In this case take measures to eliminate interferences.
- 2.3.7.2.8 The sensor should be aligned with 2 operators. When setting up the sensitivity, it is not allowed any movements of objects in the detection zone except the operator doing control passages.
- 2.3.7.2.9 The first operator does control passages in the second half of each subzone, and the second one sets the sensitivity in every subzone up to 90% ... 100% of the full column with the «Sensitivity» controllers.
- 2.3.7.2.10 The control passages should be done with minimal and maximal speed (0.3...8m/s).
- 2.3.7.2.11 After setting the sensitivity, the level of interference in any subzone should not exceed 20% of the height of the column.
- 2.3.7.2.12 When assessing the level of interference, it should be taken into account that interferences from swinging objects or vegetation may be absent in windless weather and appear with wind.
- 2.3.7.2.13 To set the necessary range of the detection zone and places of approved passages, untick the required subzones under the signal level indicators.

ATTENTION! Please avoid too high sensitivity to eliminate nuisance alarms.

To reduce nuisance alarms activate only the subzones that should be activated in accordance to the security task.

If the corresponding subzone is deactivated, there is no alarm when crossing the detection zone in this place.

2.3.7.2.14 After the set up is complete, click the button “Save” to save the configuration in the nonvolatile memory of the sensor. After that the program will switch to “Standby mode”.

To return to the factory settings, press the button “Return to the factory settings”.

2.3.7.2.15 Disconnect the cable from the USB-slot on the transceiver.

2.3.7.2.16 Close the cover of the configuration elements on the transceiver.

2.3.7.3 The remote control of the sensor implements by means of the interface RS-485. It is connected to the PC via interface converter which is delivered on request. The operation principle via RS-485 is equal to operation via USB-cable.

3 Technical service

3.1 General instructions

3.1.1 Timely and complete technical service during exploitation is one of the important conditions to maintain the sensors in working order and to keep the stability of parameters during the mean life time.

3.1.2 Technical service is not required during storage and transportation.

3.1.3 Perform all the works given in the appropriate schedule during the technical service. Correct the failures and revealed.

3.2 Safety measures

3.2.1 IT IS PROHIBITED TO PERFORM TECHNICAL SERVICE BEFORE AND DURING STORM, RAIN AND SNOW FALL.

3.2.2 IT IS PROHIBITED TO USE FAILED INSTRUMENTS OR DEVICES.

3.3 Technical service procedure

3.3.1 Technical service of the sensors previews scheduled performing of the complex of preventive works. The volume and periodicity of works are given in Tables 3.1.

Table 3.1 – Schedule and periodicity of technical service.

Technical service works	Periodicity
	month
Checking of the sensors operability	+
Checking of the sensors appearance	+
Checking of the protected sector state	+

3.3.2 Checking of the sensors operability

3.3.2.1 In order to check remotely the sensors operability, apply the voltage of 5 ... 30 V to the circuit “Remote Control” of the transceiver unit from the control panel respectively to the sensor power supply “–”. The sensor should trigger.

-
- 3.3.3 Checking of the sensors appearance
 - 3.3.3.1 Check the integrity of the transceiver unit, pay attention to the absence of dents, corrosion, damage of coating, cracks. In case of presence of corrosion signs remove it with a rag with kerosene and put an anti-corrosion agent.
 - 3.3.3.2 Check the transceiver unit for the absence of dust, dirt, snow and ice from the side of transmitting and receiving and clean them if necessary.
 - 3.3.3.3 Check the tightening of fixing parts fixing the sensor units to the pole or protected surface; tighten the fixing parts if necessary.
 - 3.3.3.4 Check the state of connection cables from the sensor unit to the junction box.
 - 3.3.4 Checking of the protected sector state
 - 3.3.4.1 Check the protected sector for the absence of foreign objects causing false alarms.
 - 3.3.4.2 Check the height of grass cover during seasonal works. In case grass exceeds the allowed height (see item. 1.2.2.1), remove it.
 - 3.3.4.3 The changing of height of snow cover on the protected site may reduce the input signal on the transceiver causing false alarms. Remove the snow or change the height of installation of the transceiver on the pole.

After changing the height of installation of the transceiver, configure the triggering threshold according to the procedures given in the present User Manual.

4 Troubleshooting guide

4.1 The list of possible failures is given in Table 4.1

Table 4.1 – The list of possible failures.

Failure, external manifestation	Possible reason	Repair
1	2	3
1. Constant alarm on the control and indication device	1. Disconnection in actuating relay circuit. 2. The supply voltage is absent or below the norm 3. The protected area doesn't meet the necessary requirements. 4. The transceiver unit is out of order.	Check the cable integrity and the accuracy of its connection. Provide the necessary supply voltage to the sensor. Inspect the protected area according to the requirements of items 1.2.2.1, 1.2.2.2 and remove the defects. Replace the transceiver unit.

Continuation of table 4.1

1	2	3
<p>2. The sensor generates nuisance alarms periodically</p> <p>3. The sensor does not generate alarms when a person crosses the detection zone.</p>	<p>1. Moving objects in the detection zone.</p> <p>2. Animals movement in the sector.</p> <p>3. Too high sensitivity.</p> <p>4. Influence of the adjacent sensor with the same frequency letter.</p> <p>1. Too low sensitivity.</p> <p>2. The transceiver unit is out of order.</p>	<p>Inspect the sector and remove interference factors</p> <p>Align the sensor according to items 2.3.7.2-2.3.7.5.</p> <p>Install the sensors with different frequency letters.</p> <p>Align the sensor according to items 2.3.7.2-2.3.7.5.</p> <p>Replace the transceiver unit.</p>

5 Storage

5.1 Store the sensors in factory package on racks in the warehouse.

5.2 Use heated warehouse with the temperature inside from plus 5° C to plus 40° C, humidity up to 80 %.

5.3 No vapour of acid, alkaline and other chemically active substances causing the corrosion are allowed in the warehouse.

5.4 Strictly follow the manipulation marks on the package during storage.

5.5 Mean shelf life time in the factory package at the temperature from plus 5° C to plus 40° C and the humidity 95 % at the temperature of 35° C is not less than 3 years.

6 Transportation

6.1 Packed sensors can be transported by vehicles on roads with asphalt covering without any limitation in distance and speed, on dirt roads up to 500 km with the speed up to 40 km/h.

6.2 Climatic conditions for transportation:

- Ambient temperature from minus 50° C to plus 60° C;
- Relative humidity up to 98% at the temperature of plus 25° C;
- Atmospheric pressure from 84 to 107 kPa (from 630 to 800 mm Hg).

6.3 Strictly follow the manipulation marks on the package during transportation.

7 Utilization

7.1 The sensors are to be utilized after expiry date. The sensors are to be utilized by the operating company according to actual standard and rules of the country.